

# XDE130 双桥刚性矿车

## XDE130 DOUBLE AXLE RIGID DUMP TRUCK



- 额定载重 Payload (kg) : 120000
- 额定功率 Rated Power (kW/rpm) : 970/1800
- 最大爬坡度 Max Gradeability (%) : 20

# 高生产率

## HIGH PRODUCTIVITY

### ● 高性能发动机 High Performance Engine

电控柴油发动机。单级涡轮增压，燃油经济性好，动力充沛；发动机监控系统可实时监控各气缸的工作状况，延长发动机使用寿命，降低使用成本；先进的全电控系统，采用双电控模块，保障发动机在不同海拔高度和负载条件下的最佳性能。

Electronically controlled diesel engine, Single turbocharged, good fuel economy, plenty of power; The engine monitoring system can monitor the working state of each cylinder in real time, extend the service life of the engine and reduce the service cost. Advanced full electronic control system adopts dual electronic control modules, to ensure the best engine performance under different altitude and load conditions.



### ● 先进的交流变频牵引系统 Advanced AC Frequency Conversion Electric Drive System

- 徐工自主集成交流变频牵引系统。  
XCMG Independent Integrated AC Frequency Conversion Traction System
- 实时功率追踪的控制策略—XTP系统。  
Real-time Power Tracking and Control Strategy — XTP system.
- 优化发动机功率使用，仅在需要时运行泵、风扇和电机等辅助部件。怠速时发动机采用节油模式，在卡车加速和爬坡时则输出更多动力。

Engine power usage is optimized by running auxiliary components such as pumps, fans and motors only when needed. Fuel is conserved when the engine is idling and more power is available to accelerate the truck and climb grades when necessary.

● **先进的行驶控制策略 Advanced Drive Control Strategy**

开发出具有徐工自主知识产权的驱动控制技术，包括粘着控制技术、防打滑驱动技术、驱动力转向自适应技术、防溜坡控制技术、电子差速技术等。可以减少卡车运行时的轮胎磨损，延长轮胎使用寿命。

XCMG has developed the drive control technology of independent intellectual property rights, including adhesion control, anti-slip drive, drive power steering adaptation, anti-slip slope control, electronic differential, and etc., all these technologies can reduce tire wearing and extend tire service life.



● **装载 Loading**

该120吨卡车可与多种电铲、液压挖掘机和轮式装载机完美匹配，通过徐工XE2800E液压挖掘机装载XDE130，可提供高生产率组合。

The 120-ton truck is a perfect match for a variety of electric shovels, hydraulic excavators and wheeled loaders. XCMG XE-2800E hydraulic excavators load the XDE130, providing a high productivity combination.

[www.wme.cn](http://www.wme.cn)



## ● 可靠的制动系统 Reliable brake system

XDE130双桥刚性矿车有以下制动模式

The XDE130 Double axle rigid dump trucks have such optional brake modes as follows

### ● 工作制动 Working brake

电制动，转子受到反向力矩，驱动电机转为发电状态，从而制动车辆，并具备倒车电制动功能。

Electric braking - The rotor receives a reverse torque to drive the motor in its power-generating state and thus brake the vehicle; moreover, it is also provided the function of electric braking during backing up.

### ● 行车制动 Service brake

全液压钳盘式制动系统，由脚踏板控制。

Full hydraulic caliper disc brake system controlled by a pedal.

### ● 装载制动 Loading brake

装卸物料时的制动模式，后轮制动，前轮释放。

Braking mode applicable to material loading and unloading, namely, the rear wheels brake while the front wheels are released.

### ● 驻车制动 Parking brake

弹簧加载，液压释放。

Spring loading, hydraulic release.

超强的制动能力，下坡制动距离仅为ISO3450要求的85%。

Superior braking ability, the downhill braking distance is only 85% as per to ISO3450 requirements.



## 舒适安全

## OPERATE IN COMFORT AND SAFE

### ● 安全可靠 Safe and reliable

符合ISO3471和ISO3449标准的FOPS&ROPS驾驶室结构，充分保证了驾驶员的人身安全。

The FOPS&ROPS cab structure conforming to ISO3471 and ISO3449 standards fully ensures the personal safety of drivers.



### ● 舒适的座椅 Comfortable seat

座椅为可调气悬浮式减振高靠背座椅，配备副驾驶座椅。

The seat is adjustable high gas suspension damping adjusters, equipped with the co-pilot seat.



### ● 内饰配备齐全 Complete interior

各种显示仪表、报警器、照明、控制开关、收音机、车载电脑、电动车窗、可倾斜伸缩式方向盘、电动风档雨刷及清洗器、着色玻璃、冷暖空调等配备齐全。

The fully-equipped cab provided all kinds of display instrument, alarm, lighting, control switch, On-board computer, electric Windows, tilting and telescoping steering wheel, electric windshield wiper cleaners, colored glass, air conditioning.



### ● 车辆监测系统 Vehicle monitor system

车辆运行数据及故障报警项目采用液晶显示器和可控仪表配合的显示方式。大尺寸彩色显示屏，界面切换简单，直观清晰，易于理解。

Vehicle running data and fault alarm project adopts touch LCD display and control instrument display mode. A large color monitor improves availability and allows easy navigation between different screens.



### ● 防爆胎设计 Explosion-proof design

驾驶室采用双层底板结构与橡塑海绵组成的复合式底板结构，具有隔音降噪、安全等特点；可在轮胎发生爆炸意外时有效保障驾驶员的生命安全。

The cab uses a composite structure with the bottom plate consisting of a thickened steel plate and rubber sponge to isolate and reduce noise, prevent tire explosion and thus ensure the safety of the driver.



### ● 追尾保护设计 Rear-end protection design

合理布置驾驶室位置和整车前后悬长度，如果发生追尾，当后车保险杠撞击到前车后轮时，保证前车货箱尾部到驾驶员有足够的的安全距离，驾驶员不会因追尾而受伤害。

Reasonable arranged cab position and front and rear suspension whole length, in the event of rear-end collision, when the rear bumper hit the front car rear wheel, the sufficient safety distance from front car rear cargo tank tail to the driver has been ensured to protect the driver from rear-end collision.



- **全景行车辅助视频系统 Full-view drive auxiliary video system**

实时获取周边视频影像，保证行车安全。

Obtain the real-time video image around the truck to ensure safe drive.



# 行驶平稳

## SMOOTH AND STEADY

- **车架 Vehicle Frame**

车架采用箱形结构纵梁和圈梁，在高承载区域使用优质合金钢铸件，适应载荷多变的恶劣作业工况；利用CAE软件对车架的强度、刚度及疲劳失效进行分析并优化，保证在提高强度和刚度的情况下尽量减重，以提高整车工作效率。按照澳标AS1554制造，重要焊缝100%经超声波探伤，保证焊接质量。

The frame adopts a box girder and ring beam structure, with cast steel components used in the stress concentration area to adapt to the adverse working conditions with the load frequently changing; the CAE software is adopted for analysis and optimization of the frame strength, stiffness and fatigue failure to minimize the weight under the condition that higher strength and stiffness can be guaranteed, so that the working efficiency of the complete vehicle could be improved as far as possible. All important welds (100%) have passed ultrasonic testing.

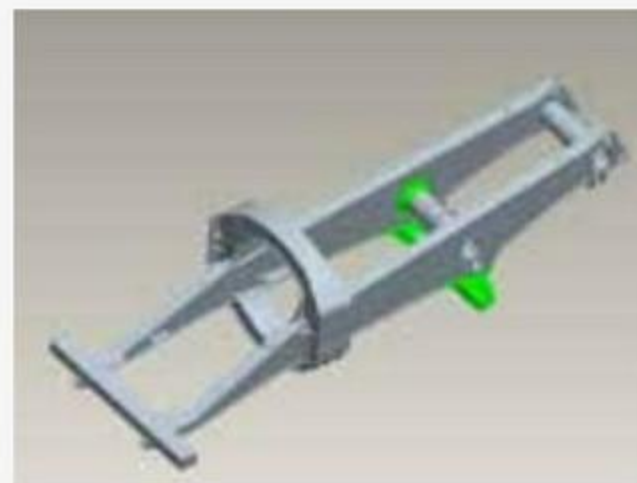

## ● 货厢 Cargo compartment

货厢选用优质耐磨板、低合金高强度钢板焊接而成，可根据用户需求及特殊应用环境实施定制化设计生产。

The cargo compartment is made of high-quality wear-resistant plate and low-alloy high-strength steel welded. Customized design and production can be implemented according to user requirements and special application environment.

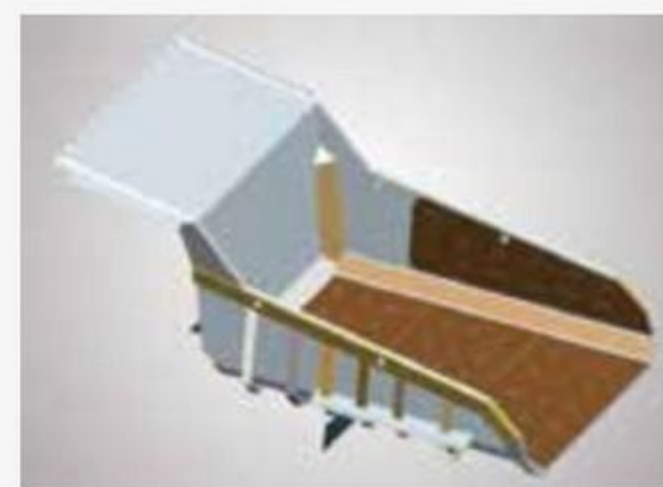

## ● 悬架系统 Suspension

- 采用4个油气比可变的氮气/油缸，减缓运输路面和装载带来的冲击，延长车架寿命。

With four oil- gas ratio variable nitrogen / cylinder, slow haul road and loading impact and prolong the life of frame.

- 前悬架采用变刚度独立烛式悬架，左右对称，保证车轮定位可靠，行驶稳定舒适。能够适应承载和路面状况的变化，快速吸收冲击，衰减振动，保证行驶平顺。

The front suspension adopts a stiffness-variable independent candle-type front suspension symmetrical on the left and right sides to ensure reliable wheel alignment as well as steady and comfortable riding, and which is able to fit changes of the load and road conditions, absorb impacts rapidly, attenuate vibration and ultimately ensure smooth driving.

- 后悬架采用纵向三角摆臂式悬架，允许后桥壳摆动，有效吸收恶劣路面产生的弯曲和扭曲应力。油/气悬架通过关节式轴承与车架和前后车桥相铰接，活塞杆外露部分由可伸缩护套保护。

The rear suspension uses a triangular longitudinal arm suspension, allowing rear axle swing, effectively absorb bending and torsion stress generated by bad roads. Oil / gas suspension through joint bearing with the frame and the front and rear axle articulated rod exposed parts of the retractable sheath protection.

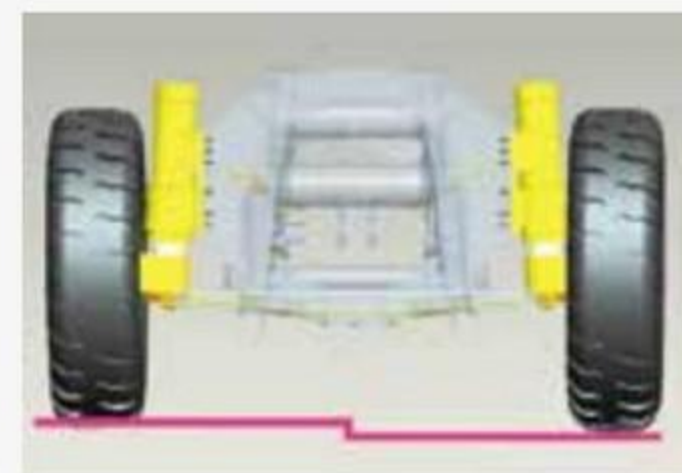

## ● 转向 Steering

进口变量柱塞泵提供转向油源，流量放大式液压转向，方向盘无路感、转向响应速度快、转向平稳，紧急转向由蓄能器提供动力。

The imported variable plunger pump provides the steering oil source, the flow amplification hydraulic steering, the steering wheel has no road feedback information, the steering response speed is fast, the steering is stable, the emergency steering is powered by the accumulator.

## ● 举升 Hoisting

双泵合流：举升时转向泵和举升泵合流，提供举升时的液压油源。

Double pump confluence: steering pump and lifting pump is confluence to provide hydraulic oil for lifting.

## ● 轮胎 Tires

选用子午线的工程轮胎，保证足够的地面附着能力，使整机获得足够的牵引力，提高了车辆的通过性。

Selection of flat tire, to ensure adequate ground area, so that the whole machine to obtain sufficient traction force, improve the passing capacity.



## ● 照明系统 Illuminating System

照明系统全部为LED灯,由前大灯、转向灯、轮廓灯、倒车灯、维修灯等组成。

The lighting system is made up of headlamps, steering lamps, clearance lamps, reversing lights and maintenance lights, etc.

照明与警示灯的位置合理，满足各种天气环境下作业时的照明与警示要求。

The lighting and warning lamps are reasonably located, able to meet lighting and warning requirements in all kinds of weather conditions during working.

控制和工作电压为DC 24V。

Control and working voltage: 24V (DC).



# 维护方便 EASY MAINTENANCE

## ● 自动润滑系统 Automatic lubrication system

自动润滑系统定期润滑各部件，减少保养时间，降低维修成本。

Controlled amount of lubricant is delivered timely to lube points, reducing service time and costs.

## ● 快速加油系统 Quick refueling system

分布在车架两侧的燃油快速加注口，接近地面，易于操作。

Quick refueling ports are distributed on both sides of the frame for quickly refueling, access to the ground, easy to operate.





## ● 安全装置 Safety Device

驾驶室配备三点式座椅安全带、逃生锤、急停开关。整车配备倒车影像系统、紧急信号灯、倒车警告、货厢安全绳、辅助转向和制动蓄能器、防滑行走表面、护栏等。

The cab is equipped with a three-point seat belt, an escape hammer, an emergency stop switch and a concentrated fire extinguishing system starter (optional). The complete vehicle is equipped with auxiliary steering and braking accumulators, non-slip walking surface, rail-guard and etc.

## ● 随机备件及工具 Supplied spare parts and tools

配备一套随机工具和易损件。

Equiped a set of carried tools and wearing parts.

# 选配 OPTIONAL

## ● 称重系统 Weighing system

- 该系统可以自动记录装载重量、装载进度等数据，帮助用户对设备产量进行准确监控。

This system can automatically record the loading weight, loading progress and other relevant data to help users accurately monitor equipment production.

- 矿车两侧安装装载进度指示灯，绿灯（50%），黄灯（90%），红灯（105%）。指示灯可以帮助铲装司机控制每次的装载量，避免矿车超载运行。

Each tramcar is equipped with a green light (50%), a yellow light (90%) and a red light (105%) on both sides to indicate the loading progress and help the driver to control the loading capacity every time to avoid overload operation of the tramcar.

- 称重系统显示屏位于驾驶室内，以数字形式和简单的英文单词显示装载数据。装载数据被记录在数据库中并可以读取。

The weighing system display in the car can show the loading data in the form of figures and simple English words. The loading data is recorded in the database and can be read.

## ● 集中灭火系统 Central fire extinguishing system

- 选用国际知名品牌的车载式半自动集中灭火系统，用于保护发动机、液压泵、高压滤芯、发电机、牵引电机、液压阀组、液压油箱出口胶管集中部位等重要设备。

An internationally famous semi-automatic fire extinguishing system is provided to protect the engine, hydraulic pump, high pressure filter, generator, traction motor, hydraulic block, hydraulic oil tank discharge hose and other important equipment.

- 两个启动器按钮分别位于驾驶室内（1个）和车架前保险杠上（1个），人工启动灭火系统。

The two starter buttons located respectively in the cab (1) and on the frame front bumper (1) can help you start the fire extinguishing system manually.

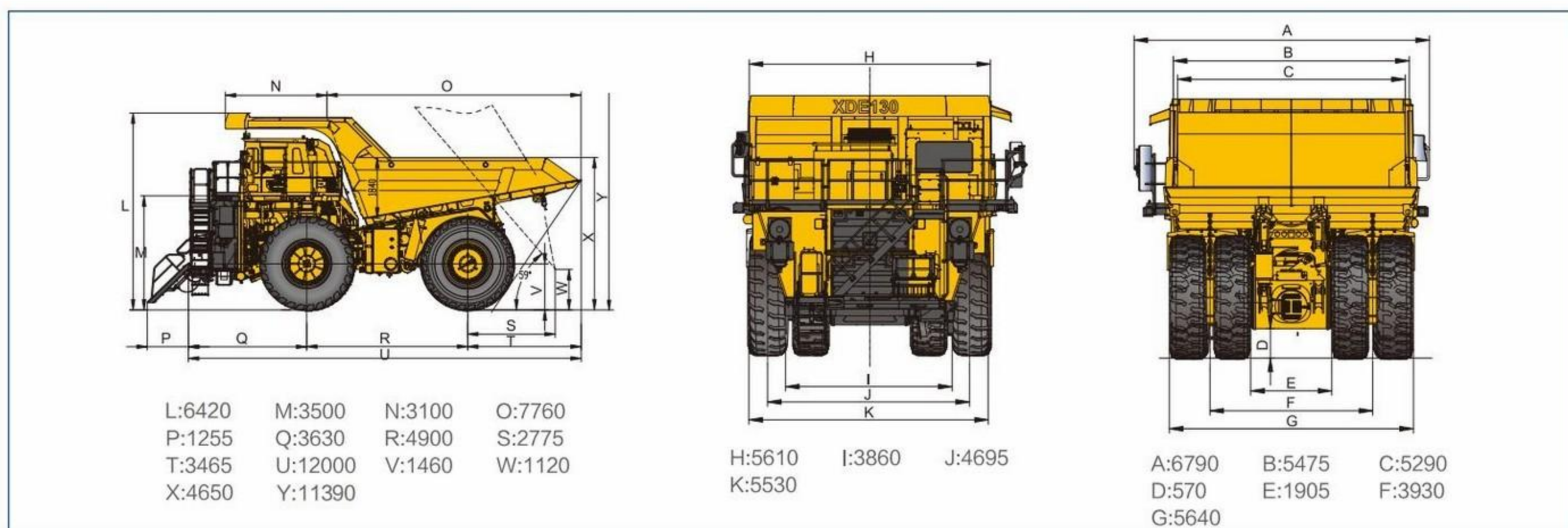

## 主要参数 / Main Specifications

项目 Item	单位 Unit	参数 Parameter
<b>尺寸参数 Dimension</b>		
整机全长 Overall Truck Length	mm	12000
整机全宽 Overall Truck Width	mm	6790
整机全高 Front Canopy Height	mm	6420/11390(lift)
轮中心距 Tire center distance	前轮 Front	mm 4695
	后轮 Rear	mm 3930
轴距 Wheelbase	mm	4900
<b>重量参数 Weight</b>		
整车总质量 Gross Vehicle Weight (GVW)	kg	205000
额定载重 Payload	kg	120000
空车重量 Empty vehicle weight	kg	85000
<b>质量分布 Weight Distribution</b>		
空载 Unload	前桥 Front axle	% 42500 (50%)
	后桥 Rear axle	% 42500 (50%)
满载 Loaded	前桥 Front axle	% 67650 (33%)
	后桥 Rear axle	% 137350 (67%)
<b>动力参数 Power Train</b>		
发动机型号 Engine	/	KTA38
发动机额定功率 Rated power	kW/rpm	859/1900
发动机最大扭矩 Max. torque	N.m/rpm	4678/1300
驱动形式 Drive	/	4×2
轮胎 Tire	/	33.00R51

项目 Item	单位 Unit	参数 Parameter
<b>行驶参数 Driving Performance</b>		
最高行驶速度 Max. vehicle speed	km/h	50
最小转弯直径 Min. turning diameter	m	23
最大爬坡度 Max. gradeability	%	20
最小离地间隙 Min. ground clearance	mm	570
<b>工作参数 Working Parameter</b>		
装载高度 Loading height	mm	5010
举升时间 Lifting time	s	16
<b>保养容量 Service Capacities</b>		
燃油箱 Fuel tank	L	1200
液压油箱 Hydraulic tank	L	650
冷却系统 Cooling system	L	330
机油 Engine oil	L	120
减速机齿轮油 (单个) Motor gear box (each)	L	40
<b>货厢容积 Body</b>		
2:1堆装 2:1 stacking	m <sup>3</sup>	73
2:1堆装 2:1 stacking	m <sup>3</sup>	90

材料和规格可随时改变，恕不另行通知  
Materials and specifications may be changed at any time without prior notice