

NTE240

Mining Truck 220-236ton



NTE240

Mining Truck

安全 **Safety**

ROPS 和 FOPS 结构设计、牵引力及防滑控制,防溜坡驱动设计保证了驾驶员在行驶和装载过程中的安全。发动机预润滑系统和低温启动监控系统有效防止了发动机的意外磨损,提高了可靠性和耐久性。

The NHL NTE240's integrated ROPS (Rollover Protective Structure)/FOPS (Falling Objects Protective Structure) cab and tractive effort, slip-slide control are designed to keep driver safe during running and loading. Pre-Lube system and low temperature starting protection could prevent engine from unexpected failure, which increase engine reliability and durability.

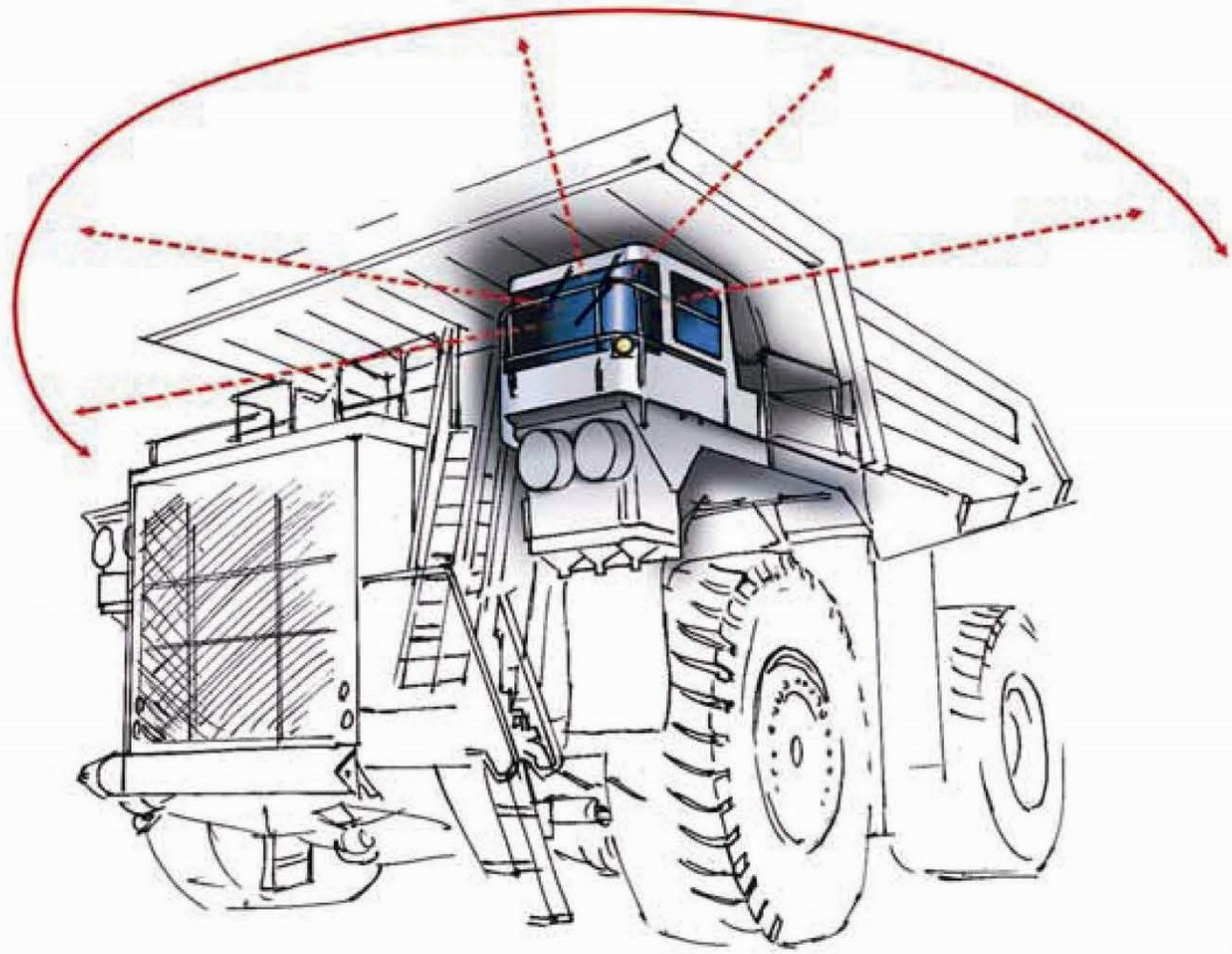

舒适 **Comfort**

可变氮/油比悬缸和前后桥的结构保证了行驶平顺性。宽大的内部空间、背光式仪表、驾驶室加压系统及空气过滤系统、全尺寸座椅保证了驾驶员的舒适性和驾驶的高效率。180度的大视角挡风玻璃,使得驾驶员视野最大化。

Variable rebound nitrogen-over-oil cylindrical suspension struts and independent front beam axle ensure a smooth ride. The cab features include big inner space, back-lit dashboard, pressurized and filtered intake air system, two full-size seats, full 180 degrees of vision which keeps driver's comfort and high productivity.

可靠 **Reliability**

针对矿山环境特殊设计的车桥、车架、车厢等结构件,选配全球知名制造商的电器元件和液压元件,保证了矿车的可靠性和寿命。双冷却电机设计、高效低耗,安全、可靠。

The specifically designed beam axle, main frame, dump body and other structures integrated with world famous hydraulic and electrical components make the NTE240 running reliable and durable. The double cooling motor design makes the system operating highly efficient, safe and reliable.

动力 **Feel the Power**

康明斯 QSK60 发动机配备 GE 240AC 电驱动系统,专为大型露天矿山设计,启动扭矩大、抗高温能力强、噪音低、维修检测方便、节能降耗。

The NTE240 equipped with Cummins QSK60 engine and GE 240AC drive systems which are specifically designed for surface mining. The power package features high starting torque, high temperature resistant ability, low noise, easy maintenance and cost saving.



发动机 Engine

制造商	Manufacturer	康明斯/Cummins
型号	Model	QSK60
冲程	Operating Cycle	4
缸数	Number of Cylinders	16
额定功率	Rated Power (SAE)	2500 hp
飞轮功率	Flywheel HP	2350 hp
净重	Weight Dry	8570 kg

飞轮功率指发动机飞轮处的额定功率减去常设附件消耗功率。附件消耗功率包括散热器风扇、发电机，泵等。标准条件额定功率符合 ISO 3046 和（或）SAE J 1995。

Flywheel HP is the rated horsepower at the engine flywheel minus the average accessory losses. Accessory losses include radiator fan, battery charging alternator and pumps. Rating based on standard conditions in accordance with ISO 3046 and/(or) SAE J 1995.



电传动系统 Drive System

主发电机	Alternator	GE 5GTA41B
驱动马达	Wheel Motor	GE 5GEB25A
电控柜	Control Group	17KG 535D
电阻柜	Resistor Grid	17EM146
轮边减速器速比	Gear Ratio	31.875:1
最高车速	Max Speed	64 km/h(40mph)
电阻个数	Number of Resistor	14
最大瞬时制动功率	Maximum instantaneous Rating	3236KW(4344hp)
最大连续制动功率	Maximum Continuous Rating	2832KW(3802 hp)

电制动系统配备风冷式电阻栅，可为电制动系统提供高效、安全、可靠的缓行力。

Electrical dynamic retarding with continuous rated blown grids, ensure retarding safe and reliable.



车架 Main Frame



车架主体由变截面的箱形直纵梁和圆柱形横梁焊接而成，直纵梁设计消除了应力集中，变截面箱形纵梁结构降低了应力，延长了疲劳寿命，圆柱形的横梁结构使车架整体抗扭性能更加优越。车架采用先进焊接工艺，提高了焊缝的耐久性，延长了疲劳寿命。

The frame features a straight rail and tubular center cross beam design to eliminate sources of stress concentration. Variable section main rails reduce stress and increase frame fatigue life. The tubular center cross beam structure enhances the torsional resistance. A submerged arc welding process further reduces stress with full-penetration weld joints, which increases frame fatigue life.



驾驶室 Cab

一体式 ROPS (防倾翻保护机构) 驾驶室, 具有内饰豪华、浅色玻璃、让视野更加开阔的流线形风挡的特点。可倾斜和伸缩的方向盘, 加热器和除霜器, 加压、过滤的换气道使驾驶员更加舒适。ROPS 驾驶室按照 ISO 3471 标准设计。在驾驶员感觉到的噪音级方面, 满足 SAE J 1166 标准要求: 在门窗紧闭的情况下, 所测得的噪音低于 82dB。

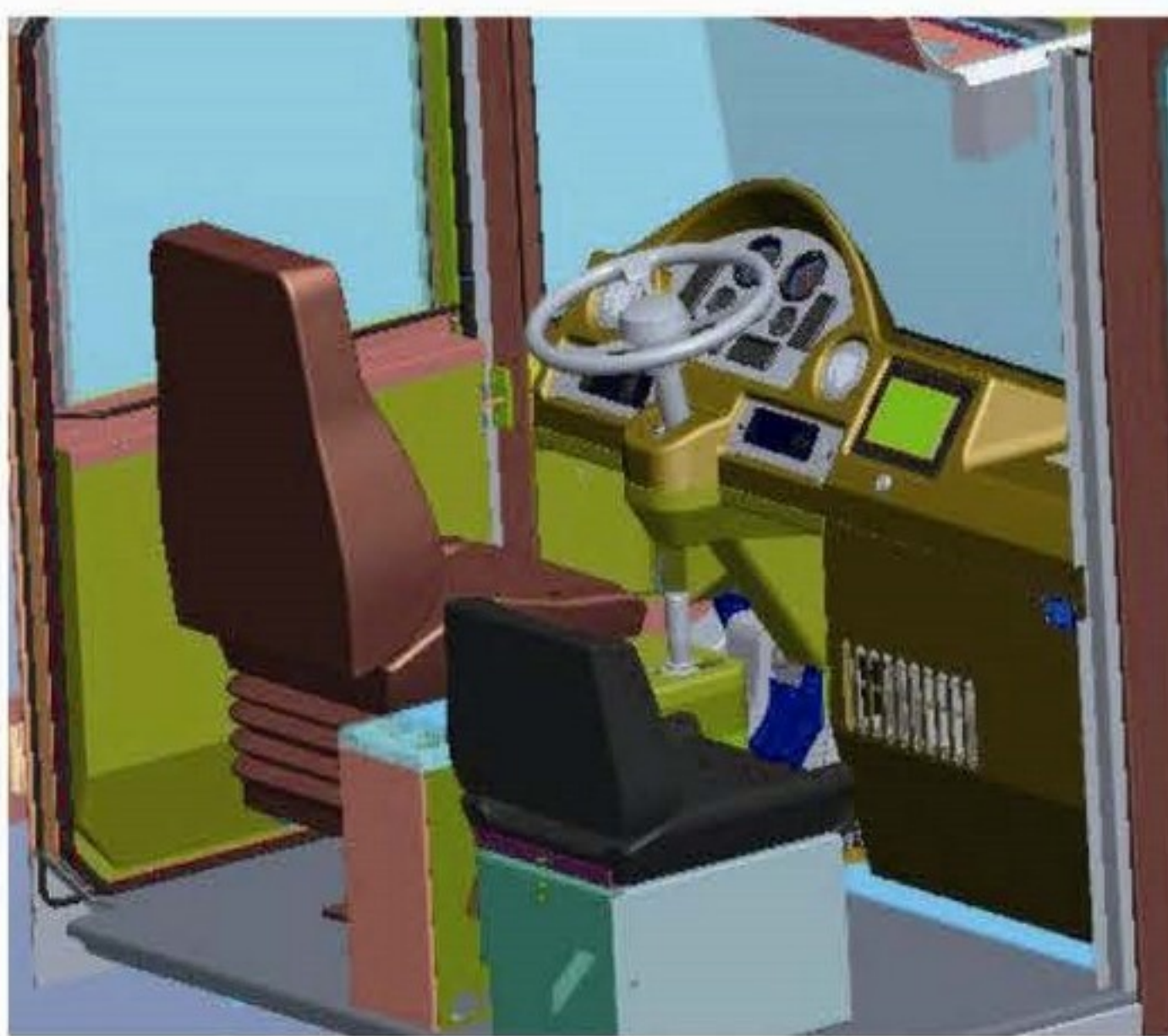
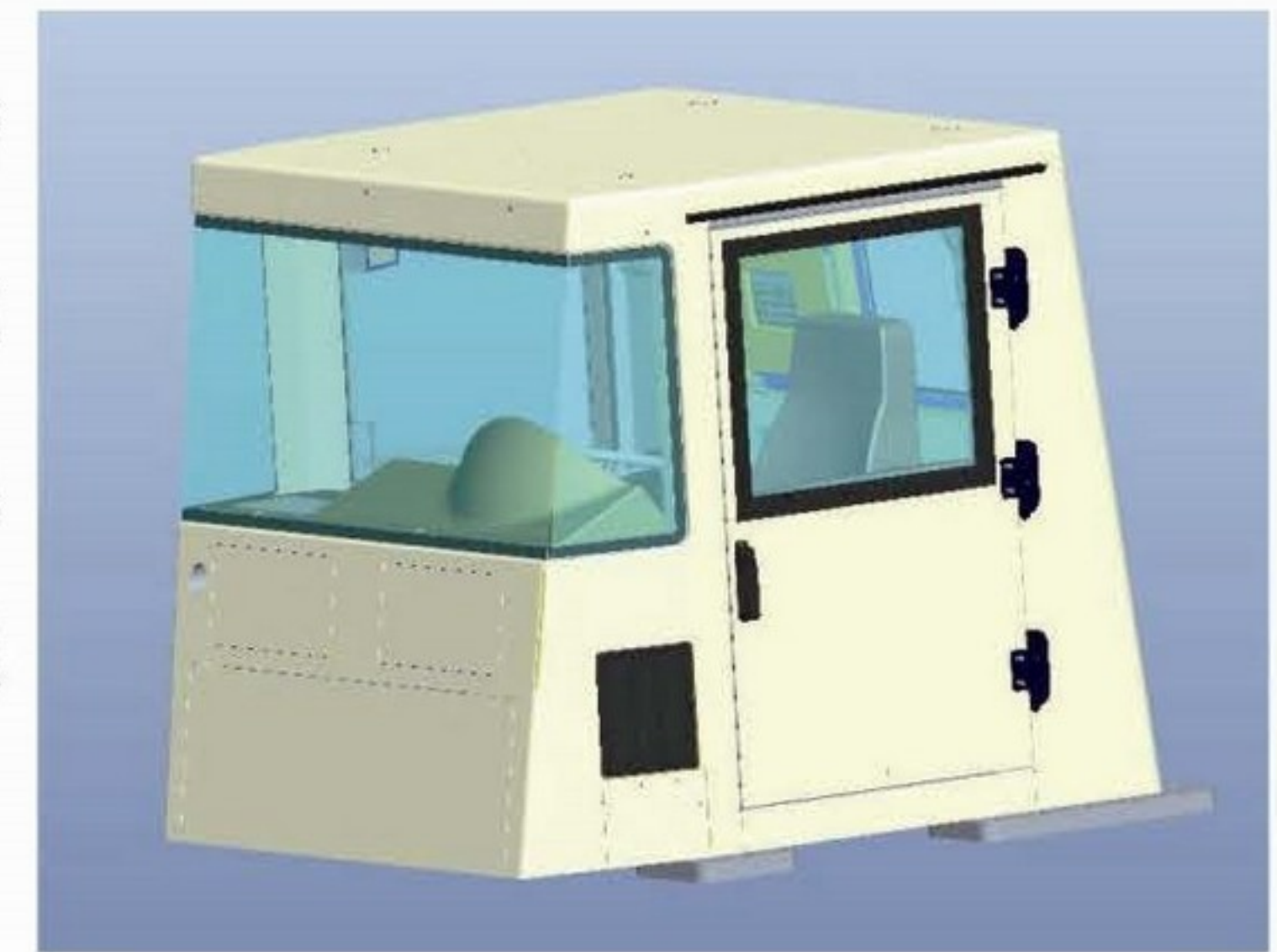

Integral ROPS (Rollover Protective Structure) Cab meets requirements of SAE J 1040. Features include deluxe interior, tinted safety glass, curved windshield for added field of view, tilt and telescopic steering wheel, heater and defroster and pressurized and filtered intake air for driver comfort. Sound exposure is at an Leq (equivalent sound level) of less than 82 dB(A) and is tested per SAE J 1166 MAY90 with doors and windows closed.



平台总成 Super Structure

一体式“工”字梁及封闭式底板结构保护了关键部件在矿车行驶过程中不受损坏。特殊设计的平台结构便于从平台上部维修发动机、电路等零部件。平台上各部件的布置使得驾驶员的视野最大化。

Rugged one-piece “工” beam construction with closed bottom protects critical components from road and mud damage. Top access to engine, piping and electrical wiring allows for easy maintenance. Deck components are located to optimize driver visibility.



前桥总成 Front Axle

前桥通过两个前悬缸、四个纵向推力杆、一个横向稳定拉杆连接在车架上, 这种布置方式不仅减少了车架的应力负荷, 而且不论前悬缸的行程如何, 都使轮胎处于正确的运动状态, 延长了轮胎的使用寿命。

The axle is pin-connected to the main frame with four drag links, two suspensions and a pan hard rod for lateral stability which could reduce the stress acted on the main frame. The tires could remain true tracking regardless of suspension stroke, extends tire life.



轮胎 Tires

标配: 50/80 R 57 子午线轮胎。

选配: 46/90R57 和 40.00R57

轮辋规格: 32.00×57

Standard: 50/80R57 ** Radial

Options: 46/90R57 ** Radial

40.00R57 ** Radial

Rim Size: 32.00 x 57



驱动桥 Axle Box

桥箱结构设计合理，减轻重量。鼻锥部件由两片轴承组成，特殊的结构降低了轴承的接触应力（小于 9653 kPa），延长了轴承的使用寿命。

The optimal designed axle box largely reduces the structure weight. Nose-cone attachment features a patented, large two-piece bearing, which reduces contact pressure less than 9653 kPa and extends bearing life.



悬挂系统 Suspension

悬挂系统由四个可变氮/油比的悬缸组成，优越的减震性能不仅为驾驶员提供了驾驶的舒适性，而且有效地缓减了物料装载、不平路面行驶对车辆的冲击，提高了矿车的使用寿命。

前悬缸冲程：12 " (305 mm)

后悬缸冲程：7.25 " (184 mm)

后桥最大摆动度：±5.7°

Four nitrogen-over-oil cylindrical suspension struts provide maximum driver comfort and minimize the impact act on the frame during loading and running on the uneven road finally maximize truck performance.

Stroke:

Front: 12 inch (305 mm)

Rear: 7.25 inch (184 mm)

Rear Axle Oscillation: ±5.7°

www.wme.cn



车箱 Dump Body

深 V 形底板结构的车厢降低了矿车重心，提高了整车的行驶稳定性；相对于底板为水平结构的车厢，它具有整体刚性大，抗变形能力更强的优点。标准岩石车厢采用 3/4 " (19 mm) 底板、3/8 " (10 mm) 侧板、1/2 " (13 mm) 前板焊接。

平装容积 (SAE) 114 m³

堆装容积 (SAE 2:1) 156 m³

工作容积 140 m³

根据物料的密度的不同，可以选择备选车厢。

A horizontal bolster deep-V floor design lowers the center of gravity of the truck and improves maneuverability. Compared with horizontal floor body, deep-V floor design is more stable and stronger.

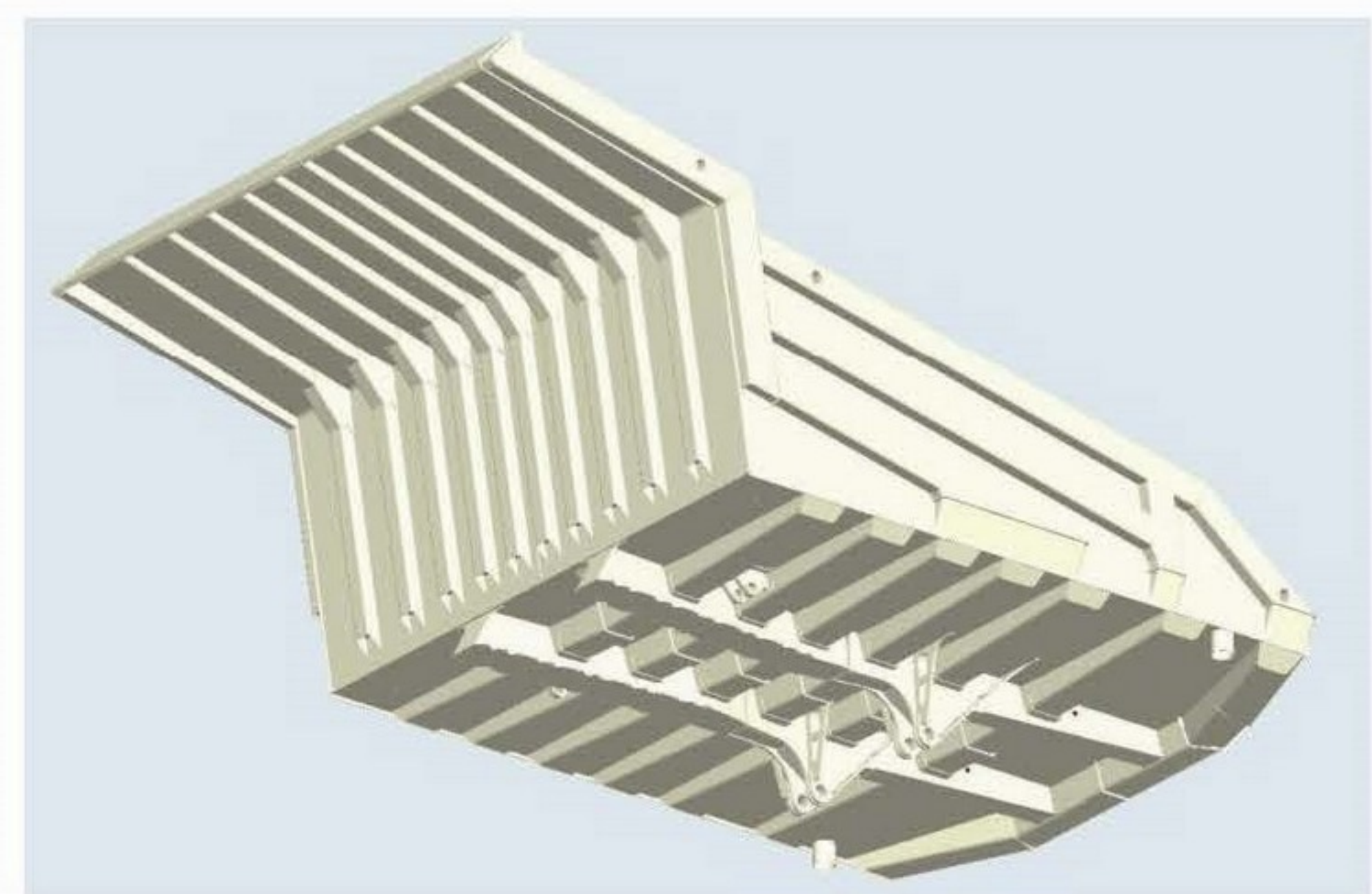

Standard rock body incorporates 3/4" (19 mm) bottom plate with 3/8" (10 mm) side and 1/2" (13 mm) front plate.

Struck (SAE): 114m³

Heaped (SAE 2:1): 156m³

Working (2:1): 140 m³

Optional body available based on material density.



转向系统 **Steering System**

全时、中闭式、负荷传感系统操纵的两个双向作用转向缸。转向系统的动力由负载传感式柱塞泵提供，并辅助两个蓄能器，当出现紧急情况时，蓄能器可向系统提供动力。符合标准 SAE J 1151 ISO 5010。

最小转弯半径 (SAE): 15.2 m

Full-time, closed center, load-sensing system operating two double-acting cylinders, supplied by accumulators that are replenished by a pressure-compensated piston pump. Auxiliary steering supplied by accumulator and meets SAE J 1511 ISO 5010.

Minimum turning radius (SAE): 15.2 m



举升系统 **Hoist System**

电控举升系统操纵两个双向作用的二级油缸，实现车厢的举升、下降、保持、浮动功能。系统动力由一个双联泵提供，为系统提供充足的压力。

满载举升时间 22 s

动力下降时间 15 s

过滤器：过滤精度为 6 微米的高压滤芯保证了系统的可靠和安全，吸油过滤是过滤精度为 100 目的粗滤网。

Electric-operated pilot system controlling a hoist valve, operating two double-acting telescoping two-stage cylinders to make the dump body power up, power down, float and hold.

Hydraulic fluid is supplied by tandem gear pump.

Power up Loaded: 22s

Power down: 15s

Filtration: High-pressure units with 6 micron (nominal) filtration assure the hydraulic system reliable and safe. Hydraulic tank inlet contains a strainer with 100 mesh screening.



制动系统 **Brake System**

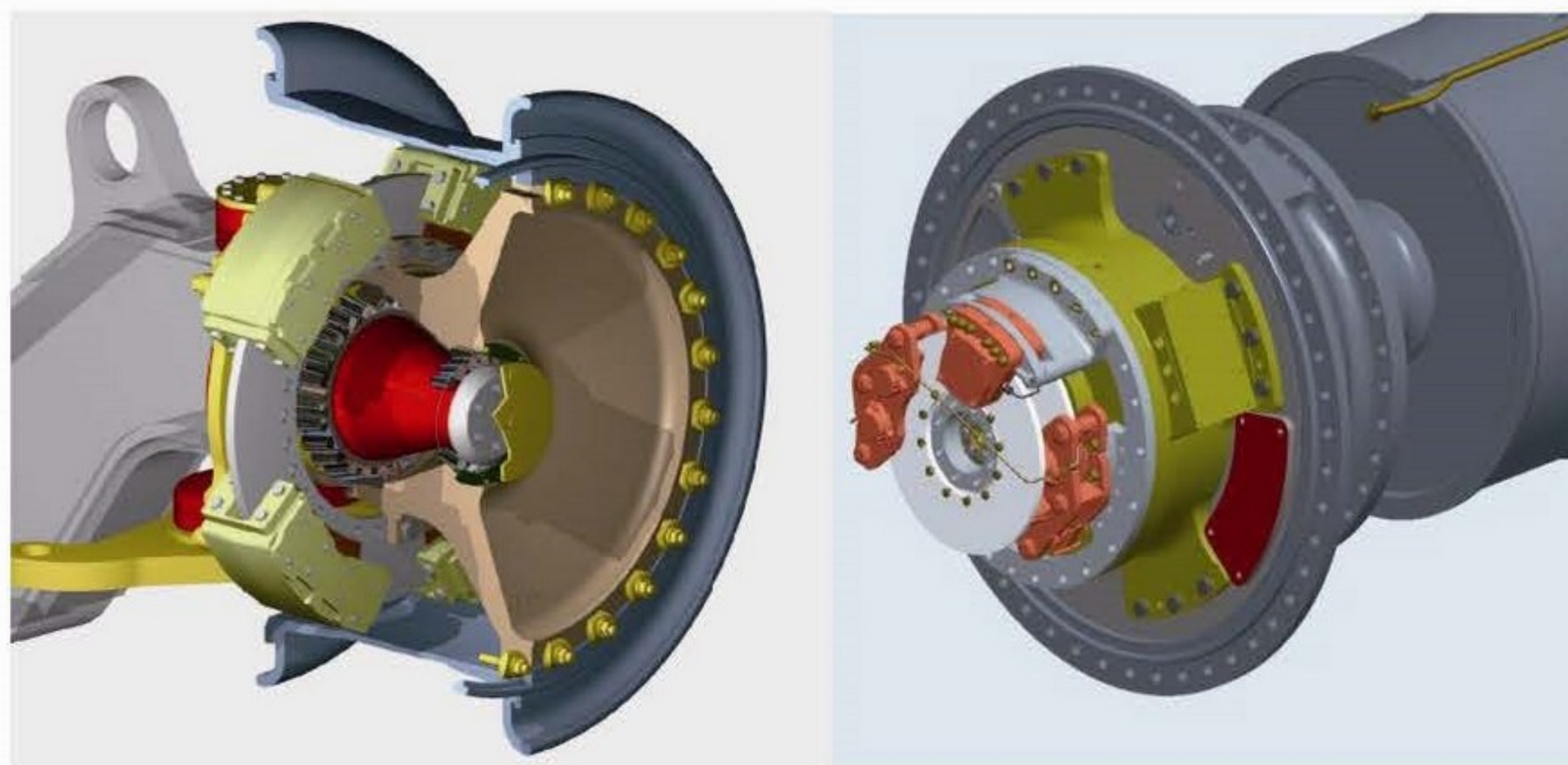

轻便的工作制动，辅助制动，装载制动，弹簧施压，液压释放的驻车制动。储能器 (3 个) 保证在紧急情况下，提供足够的安全制动。系统压力低于 2100 PSI 时，系统报警提醒驾驶员注意。

前轮 四钳盘/轮，盘直径 1168 mm

后轮 双钳盘/轮，盘直径 635 mm

驻车制动 弹簧制动，液压释放。

制动系统符合 ISO 3450 标准的要求。

Hydraulic brake actuation system features: service brakes (foot or hand operated), secondary brake (foot or hand operated), loading brake and spring apply, hydraulically released parking brake. Brake accumulators (3) could provide enough brake force under emergency situation. The system would alarm when system pressure drops below 2100PSI.

Front Brakes — 4 calipers per wheel on 1168 mm wheel speed discs.

Rear Brakes — 2 calipers per wheel on two 635 mm armature speed discs.

Park Brakes — spring apply, hydraulic release.

Braking system meets the requirements of ISO 3450.

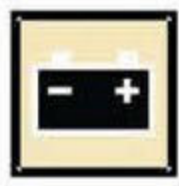

24V 电气系统 24V Electrical System

24VDC 电气系统由 6 个 12V 电瓶供电，其中两两串联然后再三组并联。电路保护系统为手动复位断路器。

24 Volt system powered by six (6) twelve (12) volt batteries (3 series pairs in parallel). Battery isolation switch standard. Equipped with manual reset circuit breaker.

照明系统	Lighting	24VDC
启动系统	Starting	24VDC
充电发电机	Alternator	260A 内置电压调节器 / 260 Amp with voltage regulator



各部位液体容量 Service Capacity

发动机机油	Engine Oil	291 L
发动机冷却液	Coolant	662 L
燃油箱	Fuel	4921 L
减速齿轮箱 (每侧)	Wheel Motor	40 L
前悬缸 (每支)	Front Suspension	36.7 L
后悬缸 (每支)	Rear Suspension	33.7 L
液压系统	Hydraulic System	908 L
液压油箱	Hydraulic Tank	662 L



重量参数 Weight

空载	Empty Vehicle Weight (EVW)	
前轴	Front Axle	86730 kg 49%
后轴	Rear Axle	90270 kg 51%
总计	Total	177000 kg
满载	Gross Vehicle Weight (GVW)	
前轴	Front Axle	136290 kg 33%
后轴	Rear Axle	276710 kg 67%
总计	Total	413000 kg



整车尺寸 Over All Dimension

单位: m

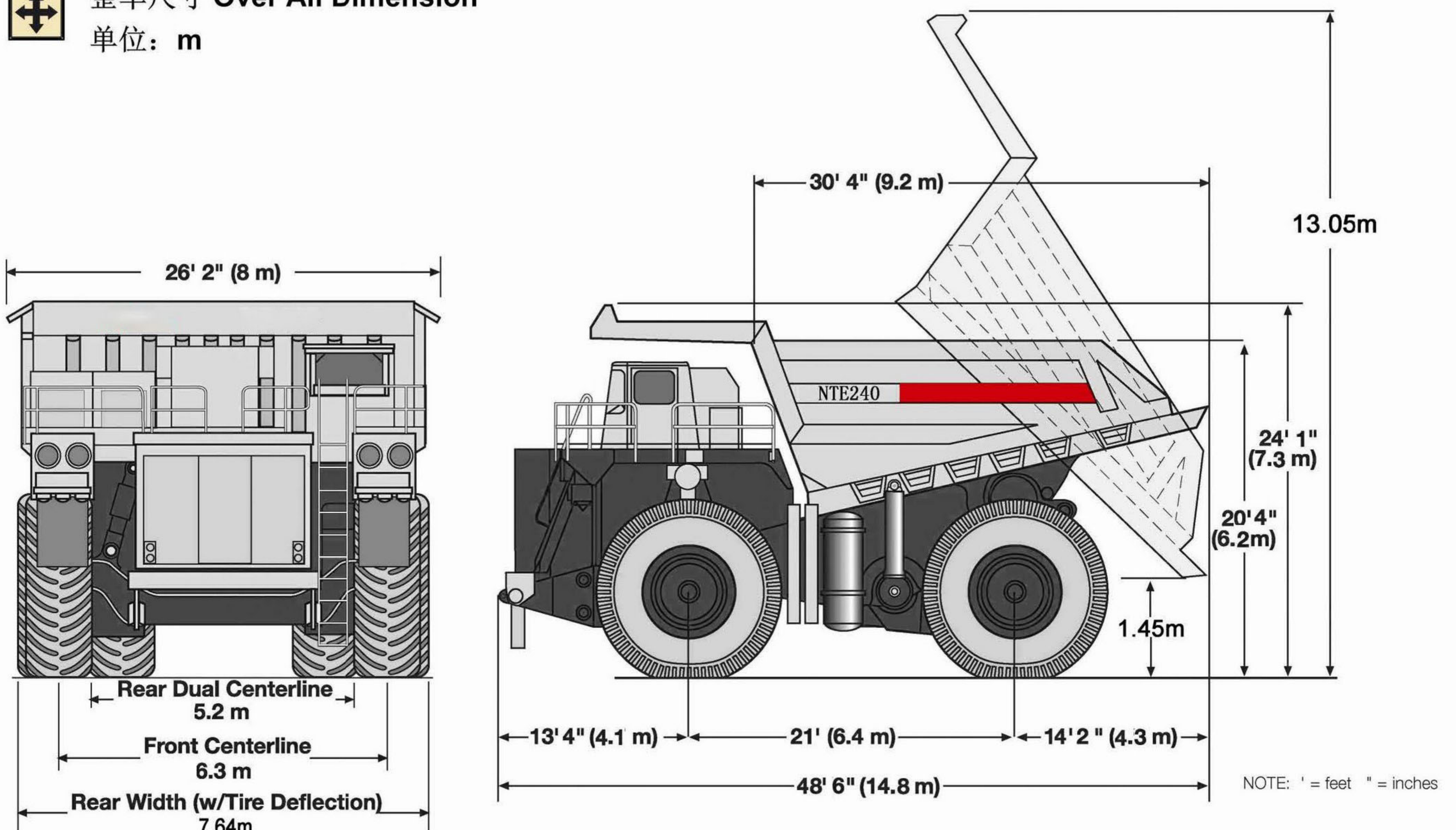

标准附件

驾驶室-

隔音内饰
门锁
地板垫
ROPS 和 FOPS 保护
电动门窗
空调/加热/除霜器
室壁灯
映照式仪表板
空气悬浮驾驶员座椅
乘员座椅
座椅安全带
可调式转向柱
遮阳板
浅色玻璃
雨刷器/洗涤剂
储物箱
收音机及 MP3 播放

控制元件-

组合开关
换挡器
远近光开关/尾灯开关
钥匙锁控电源开关
雨刷开关
装载制动开关
驻车制动开关
登梯照明开关
发动机检测开关
发动机启动/熄火开关
手制动开关

仪表组件-

发动机转速表
燃油表
小时计
发动机油压表
车速/里程表
电压表
发动机水温表
闪光指示警报器
空气滤清器阻塞
报警指示灯/蜂鸣器
发动机检测
发动机熄火

冷却风道压力
燃油油位低
液压油温高
制动压力低
液压油位低
转向压力低
电器系统故障
冷却液位低
驻车制动
车厢举升
前大灯光束
24V 发电机不充电
转向指示
高低速指示

总体-

转向/制动储能器
双级空气滤清器
举升控制
紧急制动控制
缓行控制
液压控制箱
液压油箱
燃油油位
冷却液视窗螺母
燃油位视窗螺母
发动机预润滑
低温启动抑制保护
干盘制动
消音器
卤素大灯
倒车灯/倒车蜂鸣器
转向/缓行/行车制动
举升倒车互锁
举升高速互锁
驻车制动
双回路制动
后视镜
排石链
车厢安全链
发动机维修梯
可换芯散热器
高压液压滤
快速燃油加注
平台护栏
灭火器

集中润滑

应急卸料连接
液压冷却器
温控燃油冷却器

备选附件

车厢耐磨衬板
制动自动投入
车厢加热
后部倒车监视器
集中灭火
自动称重
燃油加热
发动机冷启动系统
集中充注系统
大功率后照灯
维修照明灯
增容车厢
雾灯
前轮里程表

Standard

Cab-

Acoustic lining
Door Locks
Floor Mat
ROPS/FOPS Protection
Electric Window
A/C /heater/Defroster
Interior Light
Illuminative Panel
Air Suspension Seat
Passenger Seat
Seat Belts
Steering Column, adjustable
Sun Visor
Tinted Glass
Wipers/Washers
Compartment
Radio and MP3 Player

Controls-

Block Switch
Selector
Headlight / taillight switch
Key Switch, Power
Wiper switch
Loading Brake Switch
Parking Brake Switch
Stairway Light Switch
Engine Check Switch
Engine Start/stop switch
Hand Braking Switch

Instrumentation Group-

Engine Tachometer
Fuel Gauge
Hour meter
Engine oil pressure gauge
Speedometer
Voltmeter
Engine coolant temperature
Flashing indicator
Air Cleaner Restriction
Warning indicator light/buzzer
Check Engine
Engine Stop

Cooling duct Pressure
Low Fuel Level
High Hydraulic Temperature
Low Brake Pressure
Low Hydraulic Oil Level
Low Steering Pressure
Electric System Fault
Low Coolant level
Parking Brake
Body Hoist
Headlight Beam
24V Alternator Not Charging
Turn indicator light
High/Low Speed indicator

General-

Steering/braking accumulators
Two-stage air cleaner
Hoist control
Emergency Brake Control
Retardation Control
Hydraulic control casing
Hydraulic Tank
Fuel Level
Coolant sight glass nut
Fuel sight gauge nut
Engine Pre lube
Low-temp start- protection
Dry disk brake
Exhaust Muffler
Quartz Halogen Headlight
Reversing light /buzzer
Steer/Retard/Running brake
Hoist/ Reverse interlocking
Hoist/ High speed interlocking
Parking Brake
Two-circuit brake
Rear View Mirrors
Rock Ejectors
Body safety chain
Engine maintenance ladder
Radiator, changeable core
Hydraulic filter, High pressure
Fuel Quick Fill
Deck safety guards
Extinguisher

Central lubrication
Auxiliary Dumping Connector
Hydraulic Cooler
Temp-sensing Fuel cooler

Optional

Body Liners
Brake auto apply
Body Heating
Rear Backing-up monitor
Central fire suppression
Auto Weigh system
Fuel Heater
Engine cold start system
Central Fill System
Superpower back light
Maintenance illuminator
Body, enlarged capacity
Fog light
Front wheel odometer

参数内容如有变动，恕不预先通知

Specifications subject to change without notice

