

# KOMATSU®

## HD1500-7

**GROSS HORSEPOWER**

1109 kW **1,487 HP**

**NET HORSEPOWER**

1048 kW **1,406 HP**

**MAXIMUM GVW**

249478 kg **550,000 lb**

**HD**  
**1500**

OFF-HIGHWAY TRUCK



Photo may include optional equipment

# WALK-AROUND

## *Productivity and Economy Features*

- High performance Komatsu SDA12V160 engine  
Net horsepower 1048kW **1,406HP**
- Komatsu 7 speed, electronically controlled automatic powershift transmission
- 4-wheel oil-cooled, multiple-disc retarder
- Automatic Retard Speed Control (ARSC) standard

## *Reliability Features*

- Flat face-to-face O-ring seals
- Sealed DT connectors
- Fully hydraulic brakes -  
no air system



***Operator Environment and Control***

- Spacious cab with excellent visibility
- Ergonomically-designed cab
- Easy-to-see instrument panel
- Advanced K-ATOMiCS with “Skip-shift” function
- Built-in ROPS/FOPS cab (Level 2)
- Parking brake on input shaft
- Supplementary steering
- Push-button operated secondary brake

**GROSS HORSEPOWER**  
1109 kW 1,487 HP @ 1900 rpm

**NET HORSEPOWER**  
1048 kW 1,406 HP @ 1900 rpm

**MAXIMUM GVW**  
249478 kg 550,000 lb

***Easy Maintenance***

- Oil-cooled multiple-disc brakes and fully hydraulic-controlled braking system
- Electric circuit breakers
- Vehicle Health Monitoring System (VHMS)
- Remote mounted transmission

Photos may include optional equipment

# PRODUCTIVITY & ECONOMY FEATURES

## High Performance Komatsu SDA12V160 Engine

The Komatsu SDA12V160 engine provides the highest horsepower in its class. With 1487 gross horsepower, this engine delivers faster acceleration and higher travel speeds with a high horsepower-to-ton ratio. High torque at low speed, impressive acceleration, and low fuel consumption ensure maximum productivity. Standard features of this engine include the Quantum electronic control system, Cummins Cense monitoring and pre-lubrication.



## Seven-Speed Electronically Controlled, Automatic Powershift Transmission

Komatsu's seven-speed, electronically controlled, automatic powershift transmission uses a rubber damper to comfortably reduce harmful engine shock and vibration to the transmission. A lock-up system, consisting of a wet multiple-disc clutch, is actuated in F1-F7 gears for higher fuel savings. Electronic shift control with automatic clutch modulation in all gears and full diagnostics with memory. The transmission circuit uses a separate hydraulic circuit and cooler.

Komatsu torque converter is transmission-mounted and lock-up clutch is electronically controlled.

### Maximum travel speed (empty, 2% rolling resistance)

Gear 1	11.0 km/h <b>6.8 mph</b>	Gear 5	32.7 km/h <b>20.3 mph</b>
Gear 2	14.7 km/h <b>9.1 mph</b>	Gear 6	44.2 km/h <b>27.5 mph</b>
Gear 3	19.7 km/h <b>12.2 mph</b>	Gear 7	58.4 km/h <b>36.3 mph</b>
Gear 4	24.5 km/h <b>15.2 mph</b>	Reverse	9.4 km/h <b>5.8 mph</b>

## Four-Wheel, Oil Cooled, Multiple Disc Brakes

The HD1500-7 is equipped with four wheel, oil cooled, multiple disc brakes which provide the greatest retarding capabilities in its class. Effective and smooth braking characteristics are controlled through the retarding lever by a system of pressure proportioning valves (PPC), which precisely meter the appropriate amount of hydraulic pressure to each brake assembly. The elimination of an air system, common with dry disc brakes, improves reliability and reduces maintenance costs.

**Auto Retard Speed Control (ARSC)**

ARSC allows the operator to simply set the downhill travel speed and go down slopes at a constant speed. This allows the operator to concentrate on steering. The speed can be set at increments of 1 km/h **0.6 MPH** per click ( $\pm 5$  km/h **3.1 MPH** of setting speed adjustment) to match the optimum speed for the slope. The retarder cooling oil temperature is constantly monitored and the descent speed is automatically reduced, if necessary.



**Automatic Idling Setting System (AISS)**

This system facilitates quick engine warm-up and cab cooling/warming. When setting the system ON, engine idle speed is kept at 1000 rpm when coolant temperature is 30°C **86°F** or lower. Speed automatically returns to 650 rpm when coolant temperature goes above 30°C **86°F**.



**Small Turning Radius**

The MacPherson strut type front suspension has a special A-frame between each wheel and the main frame. The wider space created between the front wheels and the main frame increases the turning angle of the wheels. The larger this turning angle, the smaller the turning radius of the truck.

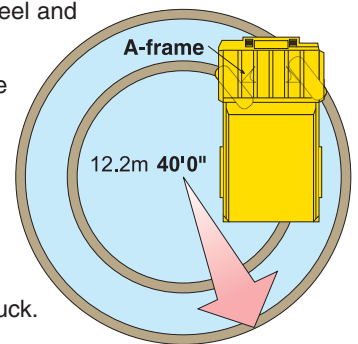

Photos may include optional equipment

# HD1500-7 OFF-HIGHWAY TRUCK

## Long Wheelbase and Wide Tread

With an extra-long wheelbase, a wide tread, and an exceptionally low center of gravity, the HD1500-7 hauls its load at higher speed for greater productivity, and delivers superior driving comfort over rough terrain.

## Large Body

A wide target area makes for easy loading with minimal spillage and more efficient hauling.

Heaped capacity : 78.0 m<sup>3</sup> **102.0 yd<sup>3</sup>**

Target area (inside length x width) :

7670 mm **25'2"** x 5705 mm **18'8"**

## Advanced K-ATOMiCS

The electronically controlled all clutch modulation system, "K-ATOMiCS", optimizes the clutch engagement oil pressure at every gear. This system optimizes the clutch lock-up process for smoother shifting with minimal torque shock.

## "Skip-shift" function

When driving uphill, the skip-shift function automatically selects the gear according to the slope of the grade. It reduces the number of down-shifts, makes the driving smoother, improves the operator's comfort, and reduces spilling of material.

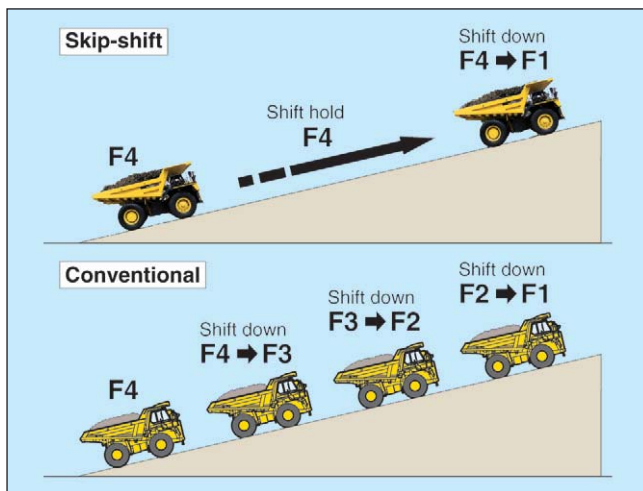

## Supplementary Steering

Automatic supplementary steering is provided as a standard feature.



## Rear LED Lighting Rack

Frame mounted LED lighting rack at the rear of the truck provides tail, brake, and flasher lights. In addition, this bracket, protected from falling objects by the body structure, includes the reverse horn and back-up lights.



## Push Button Actuated Auxiliary Brake

All four wet disc brakes are activated when the auxiliary brake button, located on the dash board, is deployed.

In addition, the brakes will automatically apply when the hydraulic pressure drops below the specified level.



## The MacPherson Strut-Type Front Suspension

The MacPherson-type independent suspension is utilized on the front wheels. This linkage arrangement allows the front wheel to follow the undulation of the road surface smoothly, realizing excellent riding comfort.

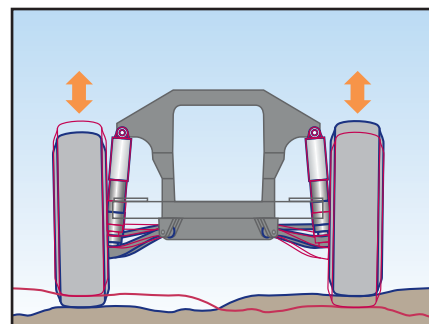

# OPERATOR ENVIRONMENT

### Spacious Cab with Excellent Visibility

The HD1500-7 cab inherits the superior design features of Komatsu's ultra-class haul trucks. Wide windows in the front, side and back, plus plenty of space in the richly upholstered interior, provide a quiet, comfortable environment for better visibility and control over every aspect of the operation.

### Ergonomically Designed Cab

The comfortable and ergonomically-designed operator's compartment makes it very easy for the operator to reach all controls. The result is more confident operation and greater productivity.

### Easy-to-See Instrument Panel

The instrument panel makes it easy to monitor critical machine functions. In addition, a caution light warns the operator of any problems that may occur. Problems are recorded in the monitor and indicated as service codes. This makes the machine more user friendly and easier to service.

### Vehicle Health Monitoring System (VHMS)

VHMS controller monitors the health conditions of major components and enables remote analysis of the machine and its operation. This process is supported by the Komatsu distributors, factory, and design team.

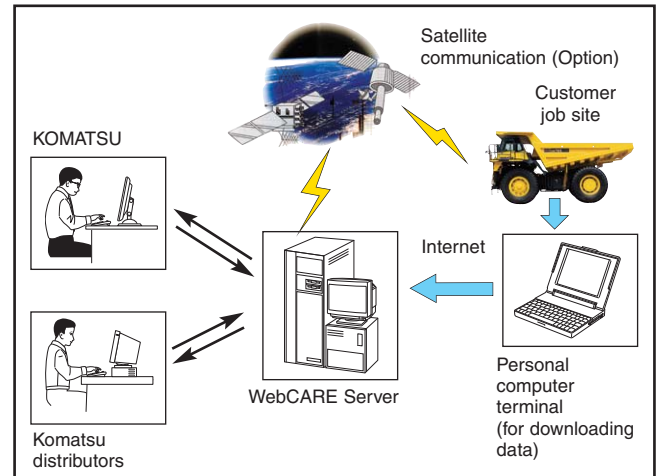

### Ideal Driving Position Settings

The 5-way adjustable operator seat and the tilt-telescopic steering column provide an optimum driving posture for increased driving comfort and more control over machine operation. The suspension seat dampens vibrations transmitted from the machine and reduces operator fatigue as well as holding the operator securely. A 78 mm 3" wide seat belt is provided as standard equipment.



Photos may include optional equipment

# HD1500-7 OFF-HIGHWAY TRUCK

## Automatic Spin Regulator (ASR)

ASR automatically maximizes traction by preventing the rear tires from slipping on either side.

## Integral Four-Post ROPS/FOPS Cab Structure (Level 2)



**Wet multi-disc brakes and fully hydraulic controlled braking systems** realize lower maintenance costs and higher reliability. Wet disc brakes are fully sealed to keep contaminants out, reducing wear and maintenance. Brakes require no adjustments for wear, meaning even lower maintenance.

Service brake and retarder are isolated from the other truck hydraulic functions to ensure reliable performance. The parking brake is a spring applied, oil released, 3 caliper dry disc mounted on the input yoke to the differential. Fully hydraulic braking systems eliminate the air system; air bleeding is not required, and water condensation that can lead to contamination, corrosion, and freezing is eliminated.

## Automatic Lubrication System

The Lincoln Auto-lube system features a deck mounted canister, ground level refill point, and an adjustable timer to ensure all pivot points are properly greased.



## Body Dump System

Two 3-stage cylinders with new concept design and sealing system. Internal cushion valve and over-center damping provide smooth, reliable dumping. The quill design modulates the body return speed after dumping to manage forces into the frame and suspensions.



## Hoist times

Power Up: 15 sec  
Power Down: 15 sec





# DASH-7 FEATURES

### Komatsu Components

Komatsu manufactures the torque converter, transmission, hydraulic cylinders, and electrical parts on this dump truck. Komatsu dump trucks are manufactured with an integrated production system under strict quality control system guidelines.

### High-Rigidity Frame

Front support is integrated with the frame. The frame rigidity has been substantially increased. As a result, flexural rigidity and torsional rigidity, which are indicators of drivability and ride quality, are significantly improved.

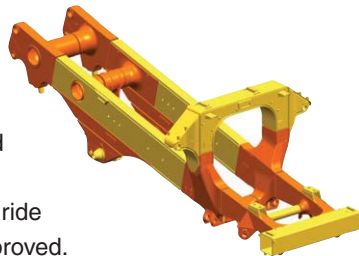

### Rugged and Durable Dump Body Design

The standard dump body is made of high-tensile-strength steel with a Brinell hardness of 400 for excellent rigidity and reduced maintenance cost. The side and bottom plates of the dump section are reinforced with ribs for added strength.



### Reliable Hydraulic System

A large capacity oil cooler is installed in each hydraulic circuit, improving the reliability of the hydraulic units during sudden temperature rises. Further, in addition to the main filter, a  $\beta_{10} = 3$  (min) line filter is located at the entrance to the transmission control valve. This system helps prevent secondary faults.

### Flat Face-to-Face O-Ring Seals

Flat face-to-face O-ring seals are used to securely seal all hydraulic hose connections and to prevent oil leakage.

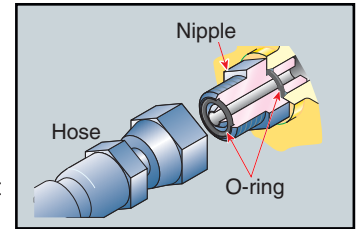

### Sealed DT Connectors

Main harnesses and controller connectors are equipped with sealed DT connectors providing high reliability, water resistance, and dust resistance.



### Protection Function Supported by Electronic Control

Item	Function
<b>Downshift inhibitor</b>	Even if the driver downshifts accidentally, a speed appropriate to the current gear is automatically set, limiting potential over-runs.
<b>Over-run inhibitor</b>	When descending grades, if the vehicle's speed surpasses the maximum for the current gear, the front and rear brakes automatically operate, limiting potential over-runs.
<b>Reverse inhibitor</b>	The vehicle is prevented from moving backward when operating the body.
<b>Forward/Reverse shift inhibitor</b>	This device makes it impossible to shift from forward to reverse when the vehicle's speed surpasses 4 km/hr <b>2.5mph</b> .
<b>Anti-hunting system</b>	When running near a shift point, smooth automatic shifting takes place.
<b>Neutral safety</b>	The engine is prevented from starting when the shift lever is not in neutral.



## SPECIFICATIONS



### ENGINE

Model	Komatsu SDA12V160
Type	Water-cooled, 4-cycle
Aspiration	Turbo-charged, after-cooled
Number of cylinders	12
Bore x Stroke	159 mm x 190 mm <b>6.26" x 7.48"</b>
Piston displacement	45 ltr <b>2,746 in<sup>3</sup></b>
Horsepower	
SAE J1995	Gross 1109 kW <b>1,487 HP</b>
ISO 9249 / SAE J1349	Net 1048 kW <b>1,406 HP</b>
Rated rpm	1,900 rpm
Fan drive type	Mechanical
Maximum torque	697 kg•m <b>5,041 lb ft</b>
Fuel system	Direct injection
Governor	Electronic control
Lubrication system	
Method	Gear pump, force-lubrication
Filter	Full-flow type
Air cleaner	Dry type with double elements and pre-cleaned, with dust indicator



### TRANSMISSION

Torque converter	3-elements, 1-stage, 2-phase
Transmission	Full-automatic, planetary-shaft type
Speed range	7 speeds forward and 1 reverse
Lockup clutch	Wet, multiple-disc clutch
Forward	Torque converter drive 1st and 2nd gear with direct drive lock-up in 1st through 7th
Reverse	Torque converter drive
Shift control	Electronic shift control with automatic clutch modulation in all gears
Maximum travel speed	58 km/h <b>36 mph</b>



### AXLES

Rear axles	Full-floating
Final drive type	Planetary gear
Ratios:	
Differential	2.647
Planetary	7.235



### SUSPENSION SYSTEM

Variable rate, hydropneumatic with integral rebound control.	
Maximum front stroke	375 mm <b>14.76"</b>
Maximum rear stroke	106 mm <b>4.17"</b>
Rear axle oscillation	+/- 9.2°



### STEERING SYSTEM

Type	Fully hydraulic power steering with two double-acting cylinders,
Supplementary steering	Accumulator assist
Minimum turning radius	12.2 m <b>40'</b>
Steering angle (left or right)	41°



### CAB

Integral 4-post ROPS/FOPS cab structure (meets SAEJ 1040 Apr 88)



### MAIN FRAME

Type	Box-sectioned structure
	Integral front bumper



### BRAKES

Brakes meet ISO 3450 standard.	
Service brakes:	
Front	Fully hydraulic control, oil-cooled multiple-disc type
Rear	Fully hydraulic control, oil-cooled multiple-disc type
Parking brake	Spring applied, oil-released, 3 caliper dry disc mounted on input yoke to differential
Retarder	Oil-cooled, multiple-disc front and rear brakes act as retarder.
Secondary brake	Manual - push button operated. Automatically applied prior to hydraulic system pressure dropping below established level.
Braking surface	159148 cm <sup>2</sup> <b>24,668 in<sup>2</sup></b>



### BODY

Capacity:	
Struck	54 m <sup>3</sup> <b>71 yd<sup>3</sup></b>
Heaped (2:1, SAE)	78 m <sup>3</sup> <b>102 yd<sup>3</sup></b>
Nominal payload	144.1 metric tons <b>158.9 U.S. tons</b>
Material	400 Brinell hardness high tensile strength steel (front, sides, and bottom)
Structure	Flat floor configuration
Material thickness:	
Bottom	19 mm <b>0.75"</b>
Front	12 mm <b>0.47"</b>
Sides	9 mm <b>0.35"</b>
Target area	
(inside length x width)	7670 mm x 5705 mm <b>25'2" x 18'9"</b>
Dumping angle	45°
Height at full dump	11440 mm <b>37'6"</b>
Heating	Exhaust heating



### HYDRAULIC SYSTEM

Hoist cylinder	Two, 3-stage telescopic type
Relief pressure	19.0 MPa 193.4 kg/cm <sup>2</sup> <b>2,750 psi</b>
Hoist time	
Raise	15 sec
Lower	15 sec



### WEIGHT (APPROXIMATE)

Empty weight	105300 kg <b>232,144 lb</b>
Max. gross vehicle weight	249478 kg <b>550,000 lb</b>
Not to exceed max. gross vehicle weight, including options, fuel and payload. Empty weight is with 100% fuel and operator.	
Weight distribution:	
Empty: Front axle	48.6%
Rear axle	51.4%
Loaded: Front axle	32.8%
Rear axle	67.2%



### TIRES

Standard tire . . . . . 33.00 R51



### SERVICE REFILL CAPACITIES

Fuel tank	2120 ltr. <b>560 U.S. Gal</b>
Engine oil	193 ltr. <b>51 U.S. Gal</b>
Hydraulic system	900 ltr. <b>238 U.S. Gal</b>
Differential	297 ltr. <b>78 U.S. Gal</b>
Final drives (total)	240 ltr. <b>63.5 U.S. Gal</b>
Transmission	153 ltr. <b>40.5 U.S. Gal</b>



**DIMENSIONS AND PERFORMANCE**

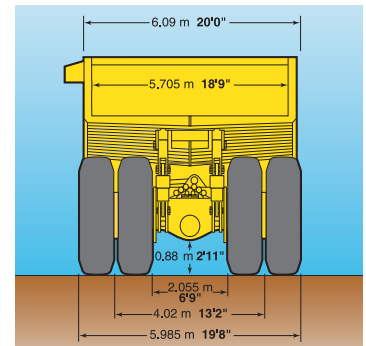
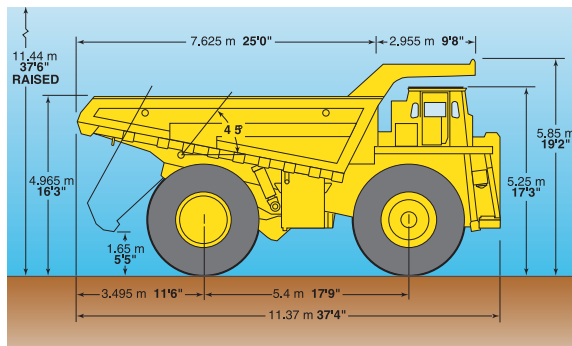
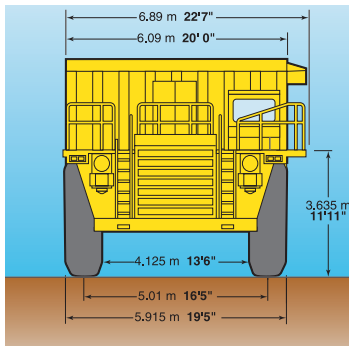

**TRAVEL PERFORMANCE**

To determine travel performance: Read from gross weight down to the percent of total resistance. From this weight-resistance point, read horizontally to the curve with the highest obtainable speed range, then down to maximum speed. Usable rimpull depends upon traction available and weight on drive wheels.

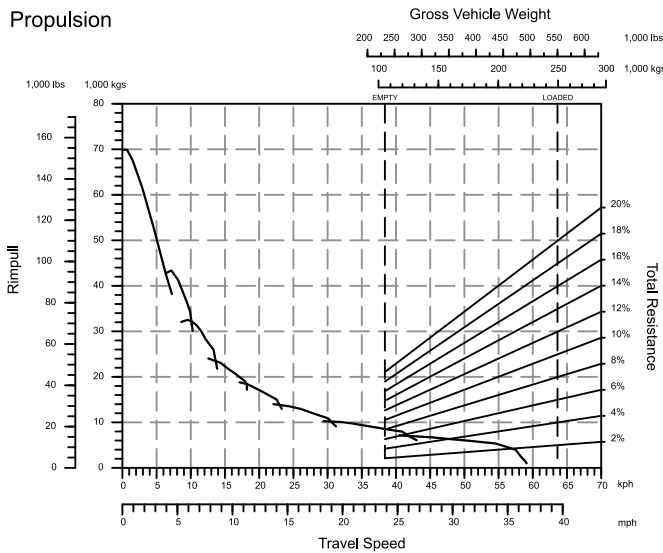

**BRAKE PERFORMANCE**

To determine brake performance: These curves are provided to establish the maximum speed and gearshift position for safer descents on roads with a given distance. Read from gross weight down to the percent of total resistance. From this weight resistance point, read horizontally to the curve with the highest obtainable speed range, then down to maximum descent speed the brakes can safely handle without exceeding cooling capacity.

**Continuous Retarding**

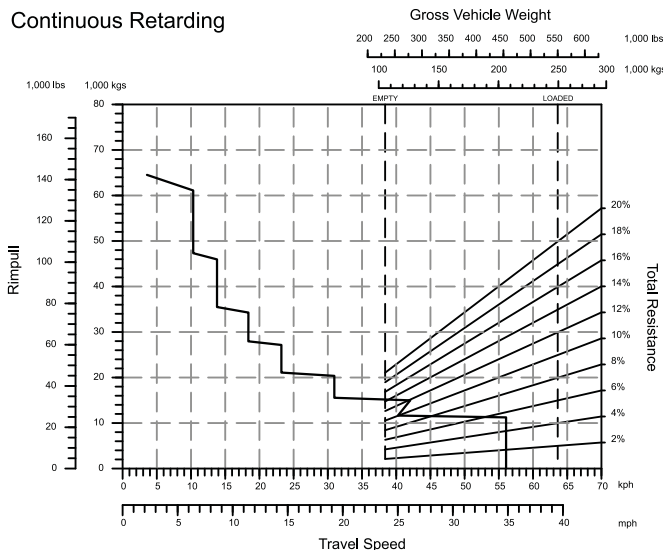

**Short Time Retarding**  
460 m (1,500 ft)

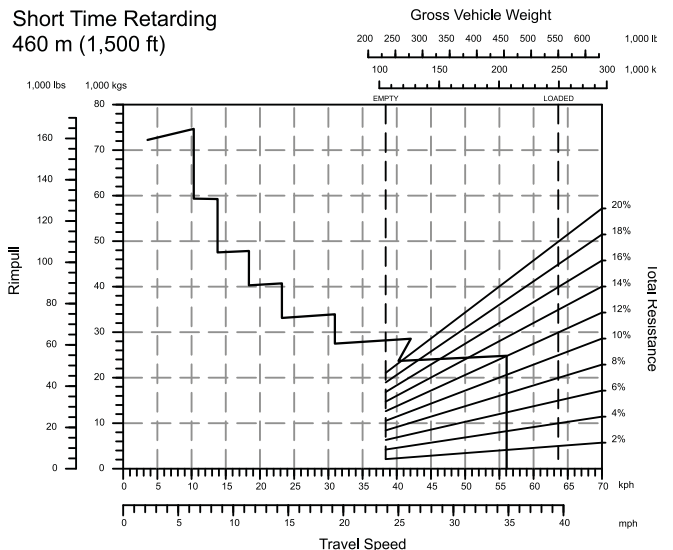



## STANDARD EQUIPMENT

### POWERTRAIN

- Air cleaner (2); battery disconnect; engine electronic control; engine electronic monitor; engine overspeed protection; engine pre-lube system; ground level shutdown; variable speed engine fan (electronic-over-hydraulic)
- Powertrain Management (these items located in the cab):
  - transmission controller
  - retard controller
  - monitor display
  - data download port
- Seven-speed automatic transmission:
  - electronic control
  - body-up reverse interlock
  - body-up shift inhibitor
  - downshift/reverse shift inhibitor
  - neutral start switch
  - transmission belly guard
- Torque converter (electronic lockup control)

### CAB

- Air conditioning (R134A)
- Electric windows (both doors)
- Glass, tinted
- Heater/defroster
- Instrumentation (gauge and monitor):
  - speedometer
  - tachometer
  - engine coolant temperature
  - brake oil temperature
  - fuel lever
  - shift indicator

- hourmeter
- odometer
- torque converter temperature
- warning lights
- Insulated and sound-suppressed
- Radio, AM/FM/Cassette
- Seat, air suspension (driver)
- Seat, passenger
- Seat belts 78 mm 3" retractable
- Steering wheel, tilt and telescopic
- Sun visor
- Windshield washer and wiper

### LIGHTING

- Back-up light, rear (1)
- Back-up lights, deck-mounted (2)
- Clearance lights, front
- Engine service lights (2)
- Headlights, halogen (8)
- Hi-low beam selector
- Instrument panel lights
- Ladder lights, driver side
- Retarder lights (2)
- Stop and tail lights LED
- Turn signals LED

### GENERAL

- Back-up warning alarm
- Body up cable
- Cab guard (on canopy)
- Drive line protector (front and rear)
- Engine fan and pulley guards
- Exhaust pipe blanket
- Ground level engine shutdown
- Handrails

- Heat shield behind engine
- Horn, electric (2)
- Ladder, deck-to-transmission
- Ladders, right and left (front)
- Mirrors, right and left
- Mud flaps
- Parking brake (3 caliper, spring-applied)
- Reverse hoist interlock
- Rock ejectors
- ROPS cab (integral 4-post)
- Secondary brake system, automatic and manual
- Skid-resistant walkway on deck
- Supplementary steering system, automatic
- Windshield, laminated safety glass

### OTHER

- Auto-Retard Speed Control (ARSC)
- Automatic Spin Regulator (ASR)
- Automatic lubrication system
- Body mounting group
- Fast fill fuel system (Wiggins) right-hand side of the machine
- Integrated Komatsu Payload Meter
- Operation, parts, and maintenance manuals (1 set)
- Rims (6), 24 x 51 (for 33 x 51 and 33R51 tires)
- Tow hooks, front
- Tow pin, rear
- Vehicle health monitoring system (VHMS)



## OPTIONAL EQUIPMENT

(Optional equipment may change operating weight.)

Weights listed are approximate change from operating weight.

Hub odometer, miles or kilometers	2 kg	5 lb
Disabled truck quick connects	13.5 kg	29.8 lb
Kim Hot Start	16 kg	35 lb
Fast fill fuel, Wiggins left-hand side	2 kg	5 lb

Fast oil change, Wiggins (engine)	7 kg	15 lb
Service center, Wiggins left-hand side	36 kg	80 lb
Muffler, deck-mounted	50 kg	110 lb
Fire extinguisher	14 kg	30 lb
Body liners		
–19 mm 0.75" floor, 9 mm 0.35" side, front and rear half of canopy (400 Brinell Steel)	8320 kg	18,340 lb

# KOMATSU®