

# KOMATSU®

## 730E-8 Electric Drive Truck

**GROSS HORSEPOWER**  
2,000 HP 1492 kW

**NET HORSEPOWER**  
1,884 HP 1405 kW

**NOMINAL GVW**  
724,000 lb 328401 kg

730E



PHOTOS MAY INCLUDE OPTIONAL EQUIPMENT



730E

# WALK-AROUND

730E-8



Photos may include optional equipment



# 730E-8

## Electric Drive Truck

### GROSS HORSEPOWER

**2,000 HP** 1492 kW  
@ 1900 rpm

### NET HORSEPOWER

**1,884 HP** 1405 kW  
@ 1900 rpm

### NOMINAL GVW

**724,000 lb**  
328401 kg



## GEB35 WHEEL MOTOR

The collaboratively designed GEB35 wheel motor features a completely redesigned gear face to achieve a longer time between rebuilds compared to its predecessors. With a standard gear ratio of 30.8:1 the GEB35 wheel motor

provides the torque needed to navigate the tough underfoot conditions found in mines around the world today.



### Productivity Features

- High performance Komatsu SSDA16V159E-2 engine
- Gross horsepower 1492 kW **2,000 HP**
- 2387 kW **3,200 HP** continuous retarding capability
- Automatic speed control (retard & propel) with automotive style cruise control
- Traction (spin-slide) control
- Komatsu designed application specific bodies
- Tight turning radius 13.6 m **44' 6"**
- Payload Meter III®

### Reliability Features

- Ultra class frame design for 181 metric ton **200 short ton** payload
- Wheel motor design based on proven GEB25 and 788
- Simple and reliable hydraulic system
- Steering and brake accumulators
- Hydraulically actuated dry disc brakes
- Compact inverter
- Solid-state retarding with quad choppers

### Environmentally Friendly

- Komatsu SSDA16V159E-2 fuel efficient engine is compliant with U.S. E.P.A. Tier 4 emissions regulations

### Operator Environment

- Ergonomically designed spacious cab with excellent visibility
- Fully adjustable driving position settings
- Four post ROPS/FOPS Level 2 Cab
- User friendly display with payload information
- AM/FM/CD/MP3/USB/Weatherband radio
- Isolated cab mounts

### Easy Maintenance

- KOMTRAX Plus allows immediate diagnostics of key engine, chassis, and drive system components
- Automatic lubrication system
- In-tank fast fuel system
- Flange type rims
- Optional smart (speed) rims

## KOMTRAX Plus

KOMTRAX Plus equipped machines can send SMR and trend information to a secure website utilizing wireless technology. Machines also relay error codes, cautions, maintenance items, fuel burn, and much more.



### Komatsu SSDA16V159E-2 Engine

The 1492 kW **2,000 hp** Komatsu SSDA16V159E-2 engine builds on the success of the SSA16V159 by incorporating the latest engine technology with more robust features. An enhanced fuel system coupled with upgraded components lowers noise and vibration for better reliability and performance.

#### New Features:

- High-pressure Modular Common Rail Fuel System (MCRS)
- Improved cold start capabilities over the SSA16V159
- Pre-lube prestart system pressurization to reduce friction and extend engine life
- Low noise and low vibration
- U.S. E.P.A. Tier 4 compliant

#### Optional Equipment:

- CENTINEL continuous oil replacement system

### Electric Dynamic Retarder

The 2760 kW **3,700 HP** retarding system provides advanced braking capacity for navigating today's mining applications which contain steep continuous descents and sharp switchbacks. Electric dynamic retarding enhances productivity and operator confidence, while eliminating the need for excessive mechanical braking effort.



### IGBT AC Drive System

The GTA49 traction alternator coupled with GEB35 wheel motors and Invertex II control system provides reliable performance and easy maintenance. Invertex II® AC control system offers independent control of the rear wheel motors, which in turn provides outstanding traction-ability during wet and slippery conditions, thus improving tire wear and operator confidence.

The air cooled Insulated Gate Bipolar Transistor (IGBT) inverter system technology provides the highest available reliability. The IGBT inverter is more compact and much simpler than the design of its predecessor, the Gate Turn Off (GTO) inverter, which improves serviceability and routine maintenance.





### Traction (Spin-Slide) Control

During slippery conditions, the 730E-8 wheel traction control technology detects and corrects wheel spin or slide events. Traction control operates automatically and independently of the service brakes. During propulsion, “wheel spin control” reduces non-productive wheel spin in low traction conditions. During retarding, “wheel slide control” prevents wheel lockup and subsequent sliding.

### Automatic Speed Control

While in retard or propel, the operator has the ability to select a comfortable travel speed. Automatic Speed Control simultaneously manages the speed of each wheel independently to allow for any immediate adjustments needed during slippery underfoot conditions.

### Komatsu Designed Application Specific Body

Utilizing the required body worksheet (BW) process, Komatsu ensures that each body is designed to meet the requirements for each specific application while carrying its rated payload. Komatsu works with each customer to understand all of the material properties at a mine site and to identify the appropriate liner package.

Komatsu offers a standard all-welded steel, flat floor body with an over the cab canopy and horizontal bolster.

- Standard Body SAE Heaped 2:1: 111 m<sup>3</sup> **145 yd<sup>3</sup>**
- Standard Komatsu Body Weight: 28169 kg **62,100 lbs**



Photos may include optional equipment



### Tight Turning Radius

By using double acting hydraulic steering cylinders with a six-point articulation linkage, the power steering system provides steering control with minimal operator effort. The turning radius is 13.6 m **44' 6"**, which provides excellent maneuverability for tight loading and dumping conditions. The steering accumulators comply with ISO-5010 standards.

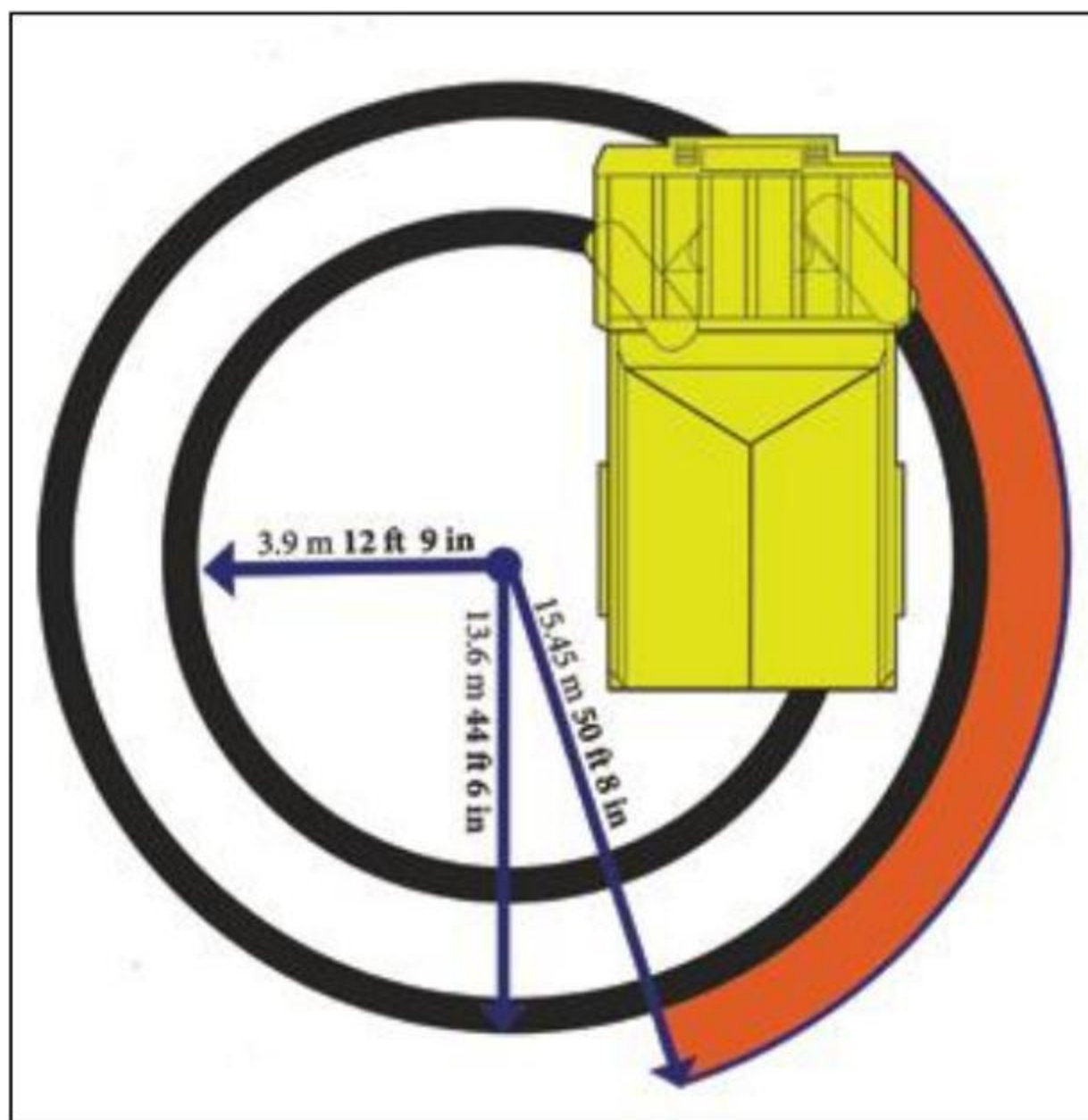

### Payload Meter III® (PLM III)

PLM III is an electronic system that monitors and records payload information for Komatsu's off-highway mining trucks. The accurate and reliable payload measurement system is designed to help optimize payload, maximize productivity and reduce the life cycle cost of the machine. PLM III tracks and records the following key production parameters:

- Payload
- Empty Carry-Back
- Operator Identification
- Haul Cycle, Loading, Dumping Time and Date
- Distance Traveled (Loaded and Empty)
- Cycle Time Information
- Maximum Speeds (Loaded and Empty)
- TMPH Estimate for Front and Rear Tires
- Average Speed (Loaded and Empty)

### Example of Payload Summary

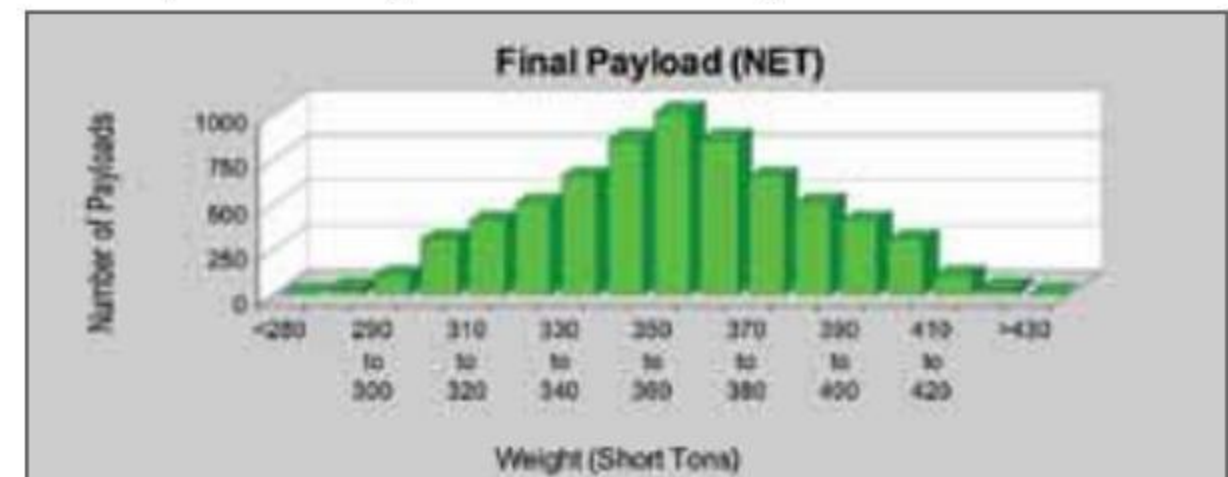

### Hydropneumatic Suspension

Hydrair II® is a suspension system that utilizes four nitrogen-over-oil cylinders. This suspension system is designed to maximize machine productivity by providing the operator with a smooth and comfortable ride. By absorbing shocks to the chassis during operation, Hydrair II® contributes to the durability of the machine's frame and components.





## OPERATOR ENVIRONMENT

### Ergonomically Designed Cab

The Komatsu 730E-8 cab design provides operators a comfortable and productive environment to meet today's mining demands. The cab features tinted safety glass windows, heating and air conditioning, acoustical insulation, double sealed doors, and filtered - pressurized air to reduce dust.

### Operator Seat

Komatsu recognizes that operator comfort is a key to productivity in today's mining environment. The five-way adjustable operator seat and the tilt-telescopic steering column provide an optimum driving posture for increased operator comfort and control over the machine. The air suspension seat absorbs vibrations transmitted from the machine, reducing operator fatigue. A blaze orange 76 mm **3"** wide three-point seat belt is provided as standard equipment.

### Built-in ROPS and FOPS Structure

Integral ROPS/FOPS Level 2 cab. These structures conform to ISO standards 3471 and 3449.



Photos may include optional equipment



### Structurally Enhanced Frame Design

By using advanced computer-aided design, finite element analysis, and full-scale dynamic and static testing, the frame design has been structurally enhanced to carry 181 tonne **200 short tons** and provides the highest reliability in the industry.

### Castings Used in High Stress Areas

To increase frame reliability, steel castings have been incorporated at key frame pivot points and critical load bearing critical portions of the frame. This includes the rear body pivot and horsecollar sections.



### Simple and Reliable Hydraulic System

The hydraulic system is a proven and reliable design with fewer parts than other OEMs. The system utilizes a single tank, providing one common source of fluid for steering, braking, and hoist actuation. In-line, replaceable filtration elements provide protection from hydraulic system contamination, making the system easier to service.

To keep downtime to a minimum, Komatsu developed a sub-frame pump module that can be removed and replaced as a single unit. This reduces change-out time and allows easy access to the hydraulic pump module.



### Steering and Brake Accumulators

In the event that the hydraulic pressure in the steering or braking system drops below an acceptable level, nitrogen-charged accumulators will automatically apply the brakes so that the truck may be stopped. There are separate accumulators for the braking and steering systems.



### GEB35 AC Wheel Motor

The GEB35 wheel motor is designed after the proven GEB25 and 788. It has a standard gear ratio of 30.8:1 and is designed for 12% equivalent grades.



### Fully Hydraulic Dry Disc Brakes

The 730E-8 comes standard with hydraulically actuated dry front wheel speed disc brakes and rear dual armature speed brakes.

- Front service apply pressure: 17237 kPa **2,500 psi**
- Rear service apply pressure: 7722 kPa **1,120 psi**

By using a fully hydraulic braking system, the formation of water and sediments - typical in air actuated braking systems - is no longer present. This prevents contamination, freezing and corrosion from affecting service brake component life.

**\*Stops in 81% of ISO 3450 allowable distance.**



Komatsu 730E-8

ISO Standard



Photos may include optional equipment



### Advanced Monitoring System – On-board Diagnostics

The Komatsu advanced monitoring system identifies maintenance items to the operator, reduces diagnostic times, indicates oil filter replacement hours, and displays fault codes to maximize machine availability and productivity.

### Automatic Lubrication System

The automatic lubrication system is designed to reduce downtime for lubrication by having a centralized location that automatically distributes grease to all lubrication points.

### Battery Isolation Station

This box contains shutdown, lockout and light switches making it easier to perform basic maintenance functions at ground level. Component switches include:

- Engine shutdown
- Access ladder light switch
- Master disconnect switch
- Starter disconnect switch
- Propel lockout lever
- LED indicator lights (on/off)



### Komatsu Smart Rim Technology

Komatsu Smart Rims allow easy removal and installation of the tires and minimize the overall impact on downtime.



\* Rim and tire maintenance can be hazardous unless the correct procedures are followed by trained personnel.

### KOMTRAX Plus

As part of a complete service and support program, Komatsu equips every mining and quarry sized machine with KOMTRAX Plus. By using a satellite-based communication system, KOMTRAX Plus offers a new vision of monitoring your valuable assets by providing insight to critical operating metrics and information that can be used to increase availability, lower owning and operating costs and maximize fuel efficiency.

The KOMTRAX Plus information available on MyKomatsu.com allows service personnel and asset owners to review cautions, operational data, fuel consumption, payloads and key component measurements provided in forms of trends. With KOMTRAX Plus, knowledge becomes the power to fuel your productivity.



### Quick Change Pump Module

To keep pump change-out time to a minimum, Komatsu has developed a sub-frame module which contains both the steering / brake and hoist pumps. This module can be removed and replaced as a single unit, helping limit potential downtime and allowing easy access to the hydraulic pumping system.

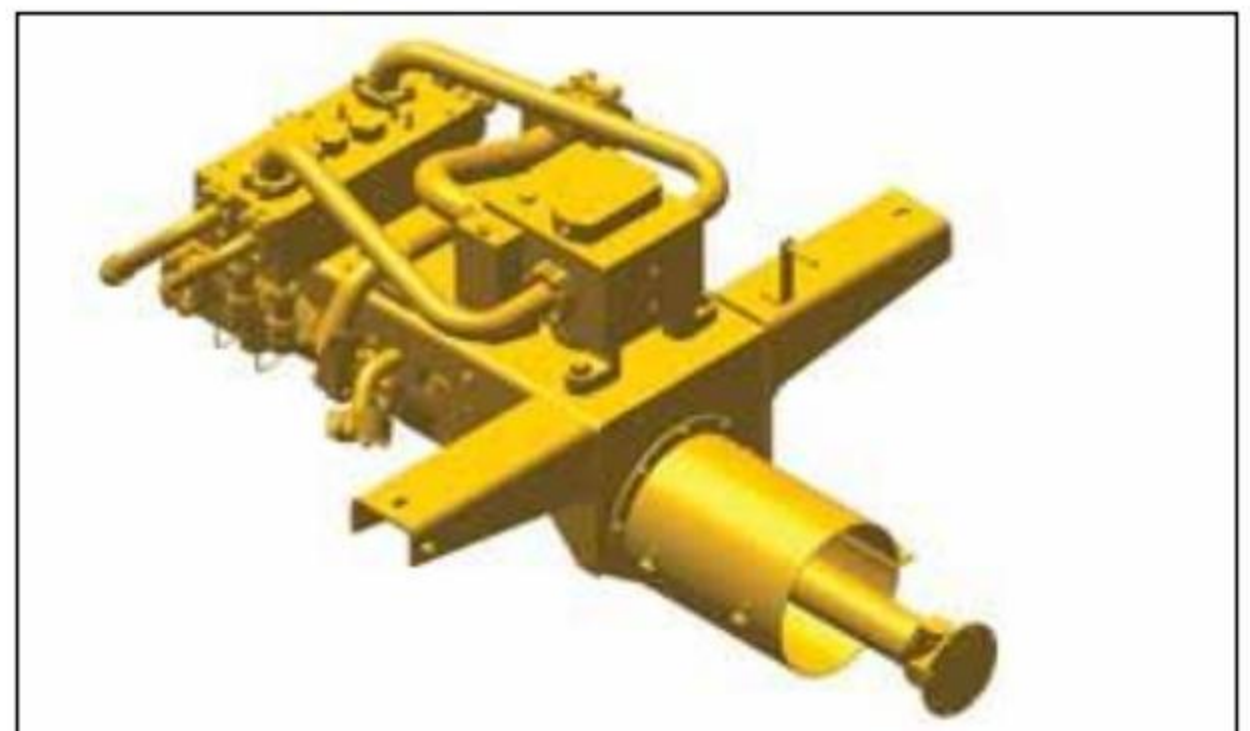



**ADDITIONAL FEATURES**

**Environmentally Friendly**

**Komatsu SSDA16V159E-2 Engine**

The Komatsu SSDA16V159E-2 engine is U.S. E.P.A Tier 4 compliant.

**Less Hydraulic Fluid Than Mechanical Drives**

The Komatsu 730E-8 contains 53% less hydraulic fluid compared to similar class mechanical drive trucks, creating a lower environmental impact and makes fluid replacement simpler, quicker, and more economical.

**Payload Policy**

**10-10-20 Load Policy Criteria**

Recognizing that variation occurs naturally in material density, fill factors, and loading equipment, Komatsu America Corp. deems it necessary to establish a consistent payload policy. This payload policy is intended to identify the guidelines and limitations for the loading of Komatsu mining trucks, and is valid for approved applications and haul profiles only.

- 1) The average monthly payload must not exceed the rated payload of the truck
- 2) 90% of all loads must be below 110% of the rated payload of the truck
- 3) 10% of all loads may be between 110% and 120% of the rated payload of the truck
- 4) No single payload may exceed 120% of the rated payload of the truck

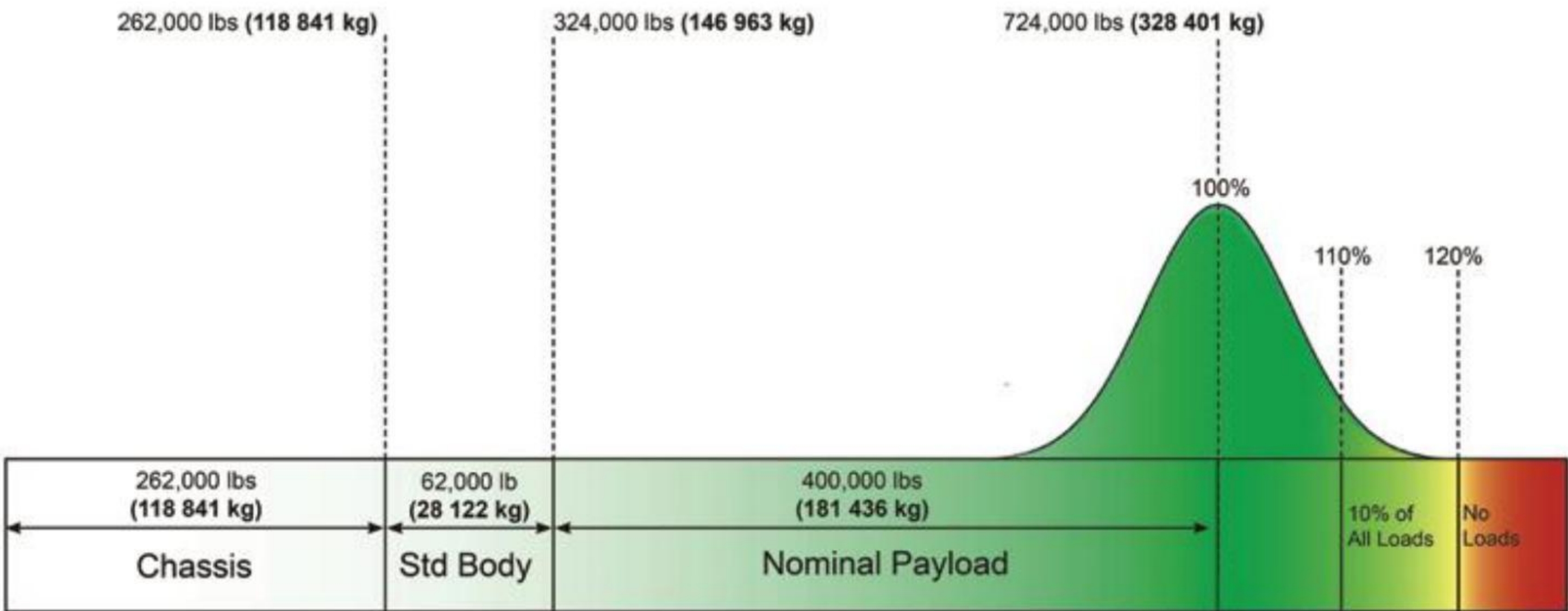







## DIMENSIONS

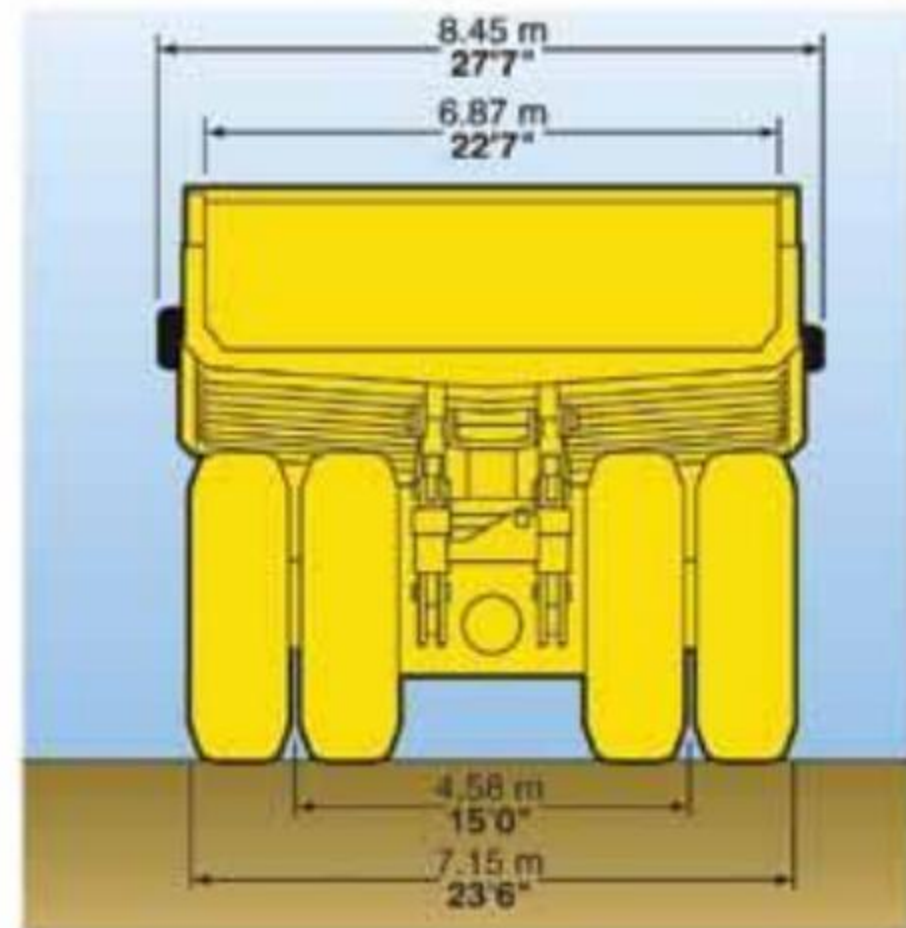
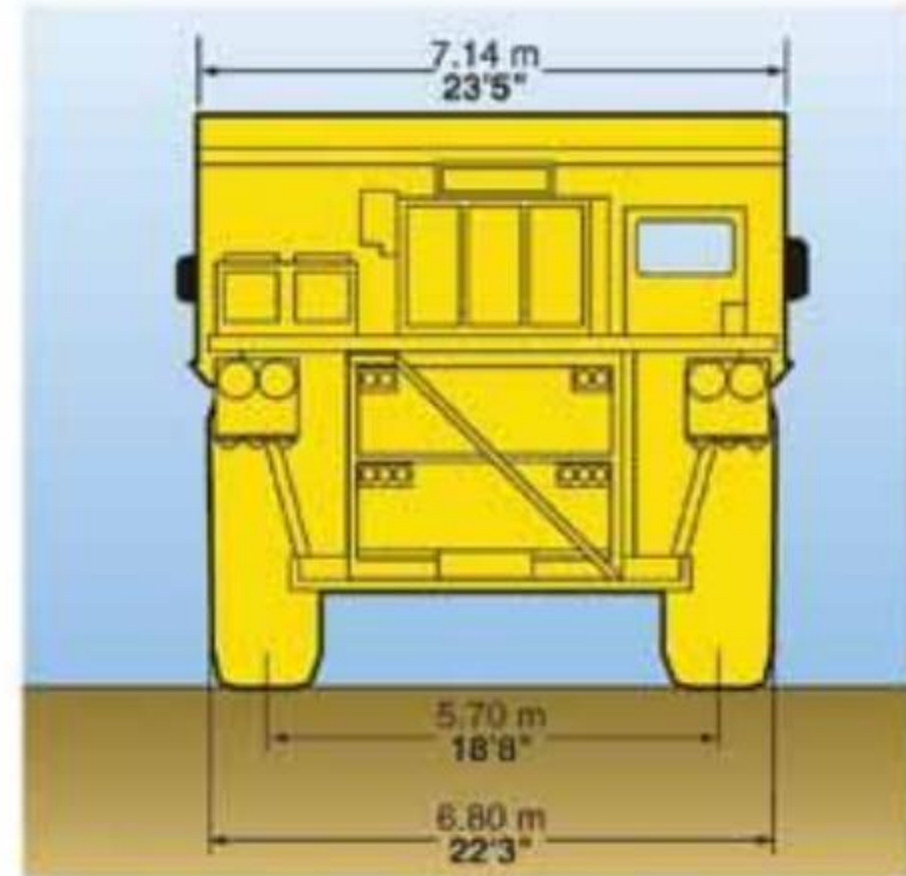
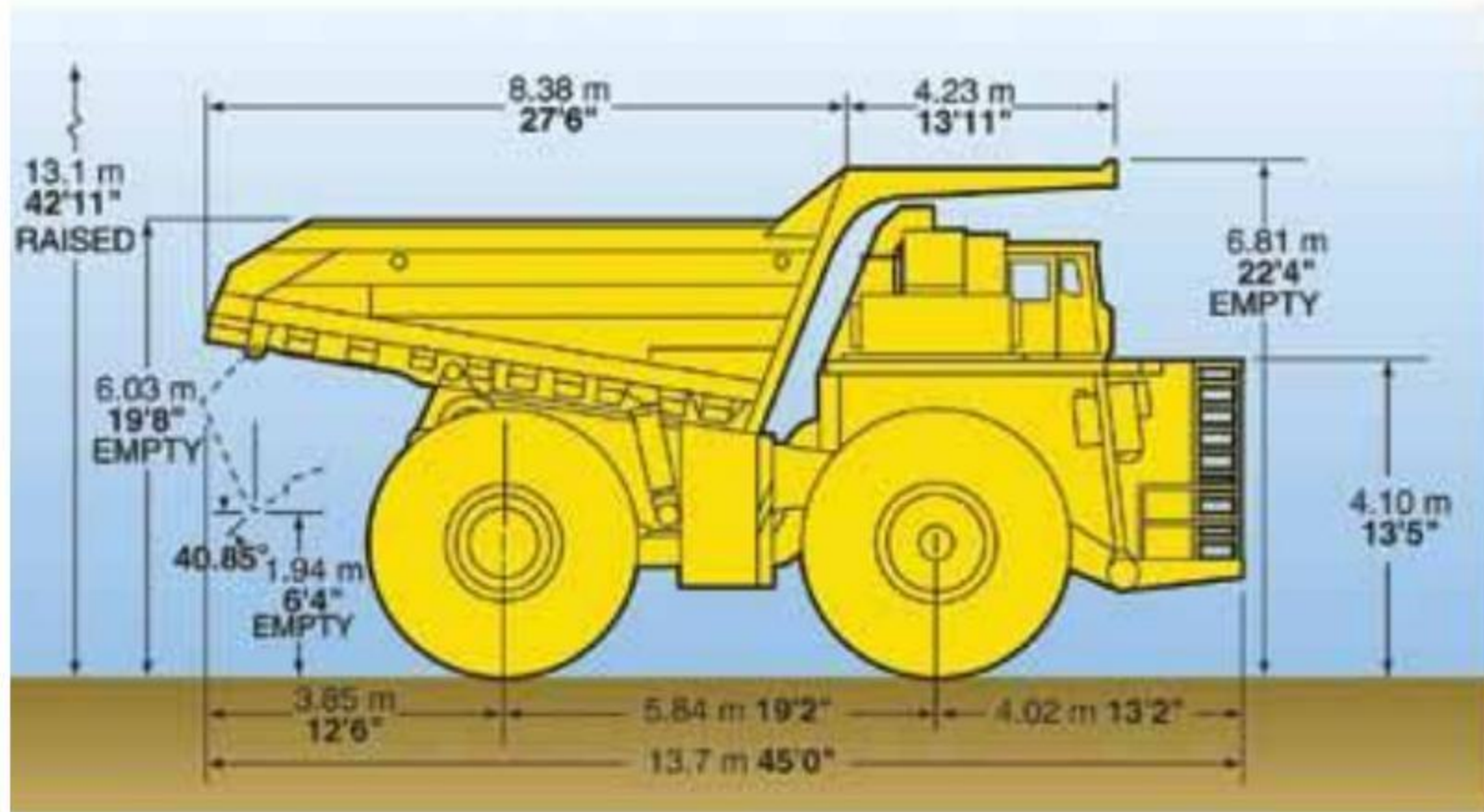

All dimensions are with standard body and tires.

Body	Capacity 2:1 Heap	Loading Height*
Standard	111 m <sup>3</sup> 145 yd <sup>3</sup>	6.03 m 19'8"

\*Exact load height may vary due to tire make, type, and inflation pressure.

## HYDRAULIC SYSTEM

- Steering ..... Accumulator assisted with twin double acting cylinders provide constant rate steering. Secondary steering automatically supplied by accumulator.
- Turning circle diameter (SAE) ..... 27.2 m 89'
- Reservoir ..... 511 L 135 U.S. gal
- Filtration ..... In-line replaceable elements
- Suction ..... Single, full flow, 100 mesh
- Hoist and steering ..... Dual, in-line, high pressure
- Brake component cabinet ..... Above deck, easily accessible with diagnostic test connections
- Hoist ..... Two 3-stage dual-acting outboard cylinders, internal cushion valve, over-center dampening
- Hoist times
  - Power-up loaded ..... 19 sec
  - Power-down ..... 10.5 sec
  - Float-down empty ..... 12 sec
- Pumps ..... Two pumps, single package, end of alternator
- Hoist ..... Tandem gear pump with output of 666 lpm 176 gpm at 1900 rpm and 17236 kPa 2,500 psi
- Steering and brake ..... Pressure-compensating piston pump with output of 254 lpm 67 gpm at 1900 rpm and 19132 kPa 2,775 psi
- System relief pressures
  - Hoist ..... 17237 kPa 2,500 psi
  - Steering and brake ..... 27580 kPa 4,000 psi

## ELECTRICAL SYSTEM

- 4 x 8D 1450 CCA, 12 volt, in series/parallel, 220-ampere-hour batteries, bumper-mounted with disconnect switch.
- Alternator ..... 24 volt, 250 amp
- Lighting ..... 24 volt
- Cranking motors ..... Two/24 volt

## SERVICE REFILL CAPACITIES

Cooling System	441 L	117 U.S. gal
Crankcase*	223 L	59 U.S. gal
Hydraulic system	795 L	210 U.S. gal
Motor gear box (each)	38 L	10 U.S. gal
Fuel	3146 L	831 U.S. gal

\* Includes lube oil filters



## Performance Chart

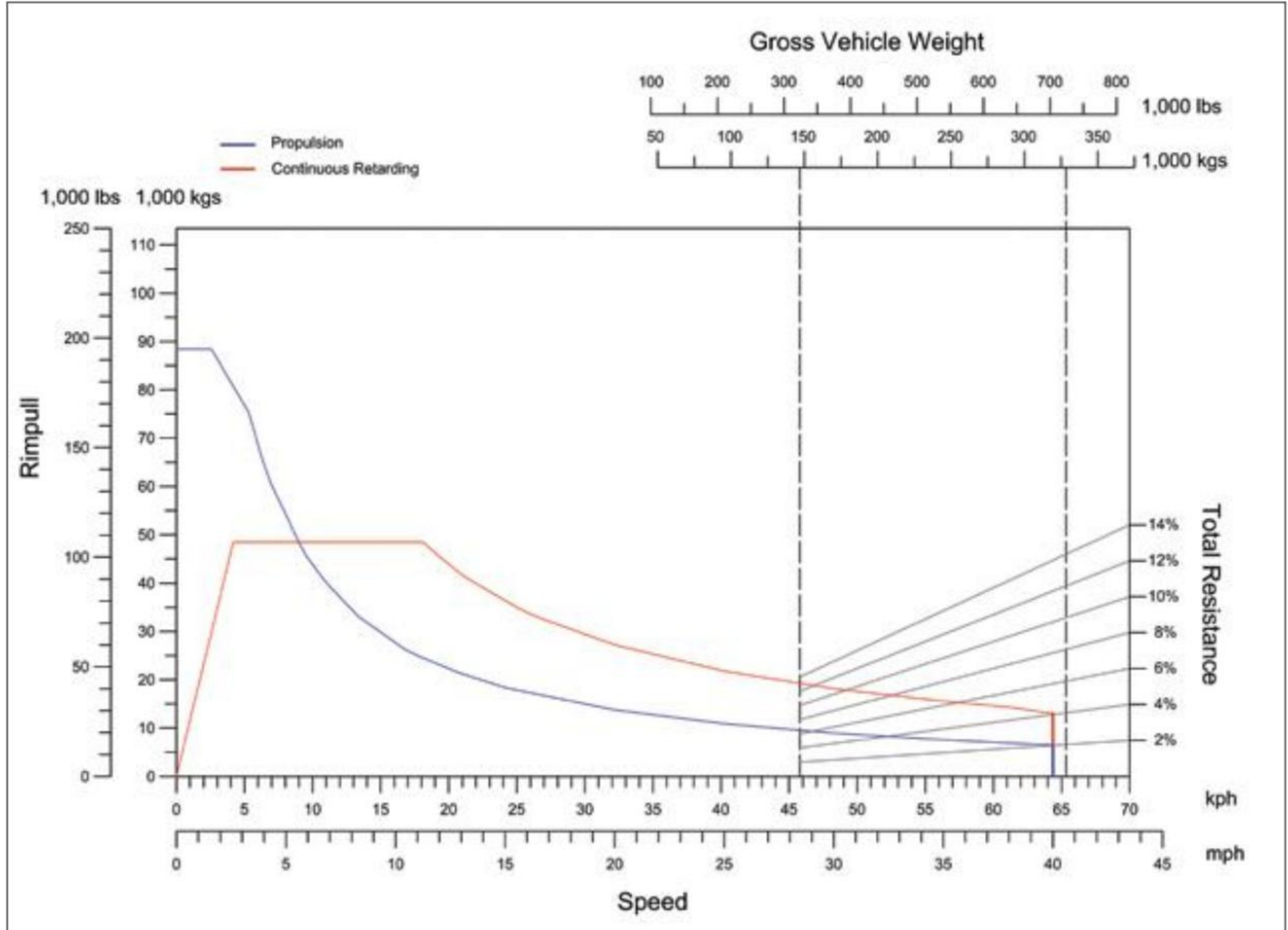

## Komatsu Product Line Loader/Truck Matching

Typical Number of Passes to Load

		Komatsu Trucks							
		HD785 100 ton	HD1500 159 ton	730E 200 ton	830E-AC 244 ton	860E-1K 280 ton	930E-4 320 ton	930E-4SE 320 ton	960E 360 ton
KOMATSU EXCAVATORS	PC2000 15.7 yd <sup>3</sup>	4	7						
	PC3000 19.5 yd <sup>3</sup>	4	6	7					
	PC4000 29 yd <sup>3</sup>	3	4	5	6	6			
	PC5500 37 yd <sup>3</sup>		3	4	5	5	6	6	7
	PC8000 55 yd <sup>3</sup>				3	3	4	4	5

Nominal truck payload rating (short tons)  
Bucket ratings are based on 1780 kg/lcm **3,000 lbs/lcy** material density.



**Empty Vehicle Weight**

Front Axle Distribution	73482 kg	<b>162,000 lbs</b>	50.0%
Rear Axle Distribution	73482 kg	<b>162,000 lbs</b>	50.0%
<b>Total EVW</b>	<b>146963 kg</b>	<b>324,000 lbs</b>	

**Gross Vehicle Weight**

Front Axle Distribution	110342 kg	<b>243,264 lbs</b>	33.6%
Rear Axle Distribution	218058 kg	<b>480,736 lbs</b>	66.4%
<b>Nominal GVW</b>	<b>328401 kg</b>	<b>724,000 lbs</b>	

**Payload**

Nominal Payload	181436 kg	<b>400,000 lbs</b>
	181 metric tons	<b>200 short tons</b>

Nominal payload is defined by Komatsu America Corp's payload policy documentation. In general, the nominal payload must be adjusted for the specific vehicle configuration and site application. The figures above are provided for basic product description purposes. Please contact your Komatsu distributor for specific application requirements.







## STANDARD EQUIPMENT

- Air cleaners, Donaldson® w/evacuators
- Alternator (24 volt/250A)
- Auto lubrication system w/ground level fill & level indicator
- Back up alarm
- Batteries—4 x 8D (1450 CCA's)
- Battery charging cable and socket
- Body impact plate
- Brakes: dry front & rear
  - Front - wheel speed disc
  - Rear - dual disc armature speed
- Cruise speed control
- Deck guard rails
- Electric start
- Fast-fill fuel system (in tank and left side remote)
- Filters, high pressure hydraulic
- Fuel tank sight gauge (3)
- Ground level radiator fill
- L&M Radiator
- Mud flaps
- Muffled exhaust—deck-mounted
- Power supply, 24 volt and 12 volt DC
- Quick disconnects (hoist and steering)
- Radiator sight gauge
- Removable power module unit (radiator, engine, alternator, blower)
- Reverse retarding
- Service center—LH
- Thermostatic fan clutch

### OPERATOR ENVIRONMENT & CONTROL

- All hydraulic service brakes w/auto apply
- Auxiliary hydraulic system
- Battery disconnect switch
- Brake lock and drive system interlock
- Circuit breakers, 24 volt
- Dedicated auxiliary circuits in operator cab (ladder lights, 2-way radios, fire suppression power)
- Diagonal staircase across grille (L to R) w/ tread
- Dimpled surface on walkways

- Dynamic retarding with continuous rated element grids
- Engine access guard rail
- Engine shutdown at ground level
- Hoist propulsion interlock
- Horns (electric—front and back-up)
- Hydraulic tank ladder
- Integral ROPS/FOPS Level 2 cab
- Isolation mounted cab
- Maintenance and power lockout
- Parking brakes with warning light & speed application protection
- Power steering w/auto secondary steering
- Radiator fan guard
- RH & LH multi-cambered convex mirrors
- Seat belts
  - Operator 3-point blaze orange 76 mm 3" retractable
  - Passenger lap 76 mm 3" retractable

### STANDARD HIGH VISIBILITY DELUXE CAB

- AC drive interface display
- Advanced monitoring system
- Air cleaner vacuum gauges
- Air conditioner HFC-134A
- AM/FM radio with CD, USB, MP3 & weatherband
- Column mounted speed control
- Digital tachometer
- Dome light
- Engine hourmeter, oil pressure gauge, coolant temperature gauge, hydraulic oil temperature gauge
- Engine shutdown w/ "Smart Timer" delay
- Floor mat (double barrier)
- Fuel gauge in cab
- Fuel low level light and buzzer
- Gauges (w/backlight)
- Headlight switch
- Heater and defroster (heavy-duty)
- Heater switch
- High beam selector and indicator

- Horn (center of steering wheel)
- Indicator lights (blue)
  - Engine service
  - KOMTRAX Plus snapshot (IM)
- Insulation (Max R-Value)
- Komatsu Payload Meter III®
- KOMTRAX Plus with ORBCOMM
- Operator seat, adjustable w/air suspension, lumbar support and arm rests
- Panel lighting (adjustable)
- Passenger seat, mechanical suspension
- Power windows
- Pressurized cab air system w/fan on
- Separate brake and retarder pedal
- Starter key switch
- Sunvisor (adjustable)
- Tilt & telescoping steering column
- Voltmeter (battery output)
- Windshield (tinted plate)
- Windshield wiper (dual) and washer (electric)

### LIGHTING

- Auxiliary box (LED)
- Back-up lights—R and L - deck mount (2) halogen
- Brake and retard lights on top of cab (LED)
- Brake cabinet (LED)
- Clearance lights (LED)
- Control cabinet service light (LED)
- Dynamic retarding, rear (2) (LED)
- Engine compartment service lights
- Fog lights (2) halogen
- Halogen headlights- all high & low beam positions (10)
- HID-style backup/ berm light
- Payload lights R and L (LED)
- Platform lights R, L and Center
- Recessed corner marker/ signal lighting (LED)
- Stairway lights
- Stop & tail lights (4) (LED)
- Turn signals (LED)



## OPTIONAL EQUIPMENT

Note: Optional equipment may change operating weight.

- Accumulators (cold weather)
- Body Liners\*
- Bumper mounted headlights
- Extended canopy
- Eyebrow
- Fire extinguisher 9 kg **20 lb**
- Heated body
- Hot start engine coolant (220V 2-2500W)
- Hot start engine oil (220V 2-500W)
- Hot start hydraulic oil
- SRI 3 point seat
- Komatsu Retractable Ladder System
- LED headlights
- Mudflaps on hydraulic tank & fuel tank
- Scoreboard PLM III Display
- Service center—RH
- Shutters (radiator)
- Smart (speed) rims
- Special language decals
- Suspensions, cold weather
- Wiggins Quick Fluid Fill & Engine Oil Evacuation System

\*Available factory installed or non-installed. All other options and accessories listed are available factory installed only.